

**SPECIAL & FABRICATED BELTS**  
**Covers, Cleats, False Teeth,**  
**PPJ System, Special Modifications**



Megadyne offers a variety of coverings in Polyurethane, elastomer, foam, PVC and other unique solutions. See below some examples. Choose the covering that interests you or request for more information to our OEM team, we will suggest the right solution.



**AVAFC 60/70/85 Sha** - Cover is used for conveying abrasive materials, with high friction especially on smooth and dry surfaces, with good (60 & 70 ShA) to very good (85 ShA) abrasion resistance.

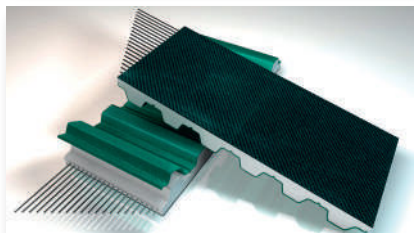

**NFT/NFB NYLON FABRIC (TEETH AND BACK)** - NFT/NFB offers low friction for accumulation as well as low noise benefits and is usually applied by Co-extrusion on base belts. Antistatic version in black color available.



**APL** - Seamless Cover used as an alternative to Natural Rubber offering a high friction and good resistance to oil and water.

**RED GRIP** - Seamless Cover used as an alternative to Natural Rubber offering a high friction and a very good oil and abrasion resistance. Only available on Megaflex.

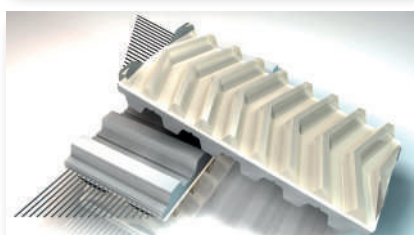

**PU FISHBONE** - Cover suitable for wet environments as in the glass industry where friction and drainage are necessary. Very good water and abrasion resistance.



**PU RIBBED** - Cover with reduced contact points for conveying sensitive products in material handling applications with very good water and abrasion resistance. Allows drain of liquids.

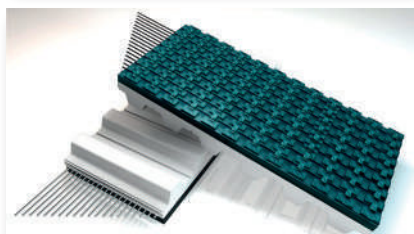

**SUPERGRIP PETROL** - PVC Cover with high CoF, applicable for slight height compensation, low shock absorption capabilities. Improved adhesion even in case of moisture and dirt - for incline, feed and take-a-way conveying applications. Seamless weldable on Megalineer and Megaflex.

## COVERS

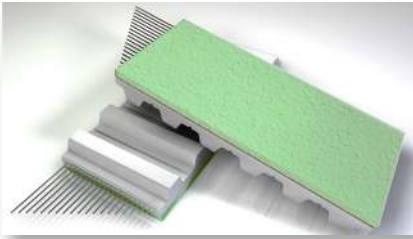

**SYLOMER BLUE, GREEN, BROWN** - Cover with low density offers high dynamic load capacity for light and sensitive parts up to top pressure belts and glass moving applications with a good water resistance.

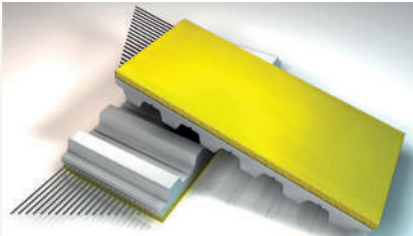

**PU YELLOW** - Sprayed endless, available in different hardness and colours Widely-used foam with very good abrasion resistance. Used in paper and glass industry. Due to easy mechanical processing very popular for vacuum transport application.

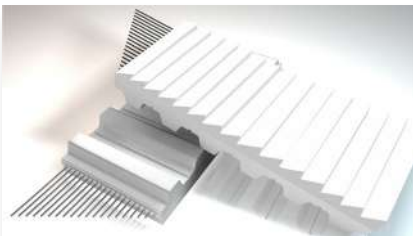

**PVC SAW TOOTH** - FDA clear pattern for improved adhesion under wet conditions Line contact, resistant against acids and bases.

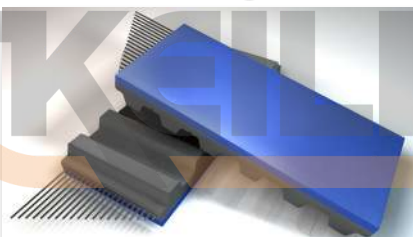

**BLUE GRIP** - NR/BR Cover 57 ShA with a improved abrasion resistance and a high friction. Universally applicable as alternative to Natural Rubber. Only available on rubber base belts.

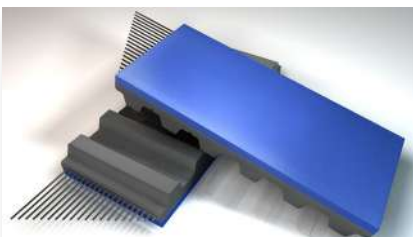

**HTX - SILBLUE** - Cover offers high temperature and UV resistance. Non-marking compound common used in printing applications. Only available on rubber base belts.

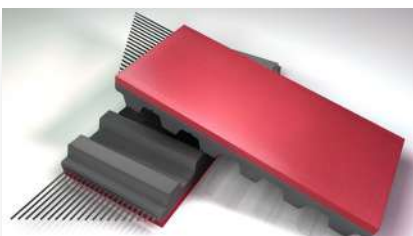

**RED NATURAL RUBBER 40** - Cover offers low durometer ShA and very good high friction; applicable on any kind of conveyor or feeding application.

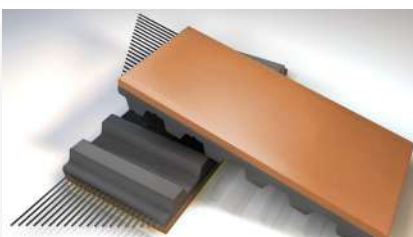

**DURATAQ®** - Natural Premium Rubber Cover with specific designed compound to reach a very good abrasion resistance with a very high coefficient of friction. Successfully installed in medium and heavy load conveyance as cable puller applications.

Megadyne timing belts can be customised by vulcanizing profiles vulcanized on their back. All the cleats are made using thermoplastic polyurethane. The cleats are attached using high frequency vibration welding. The production process for these profiles is very flexible; Megadyne can design any profile to meet the specific customer requirement.

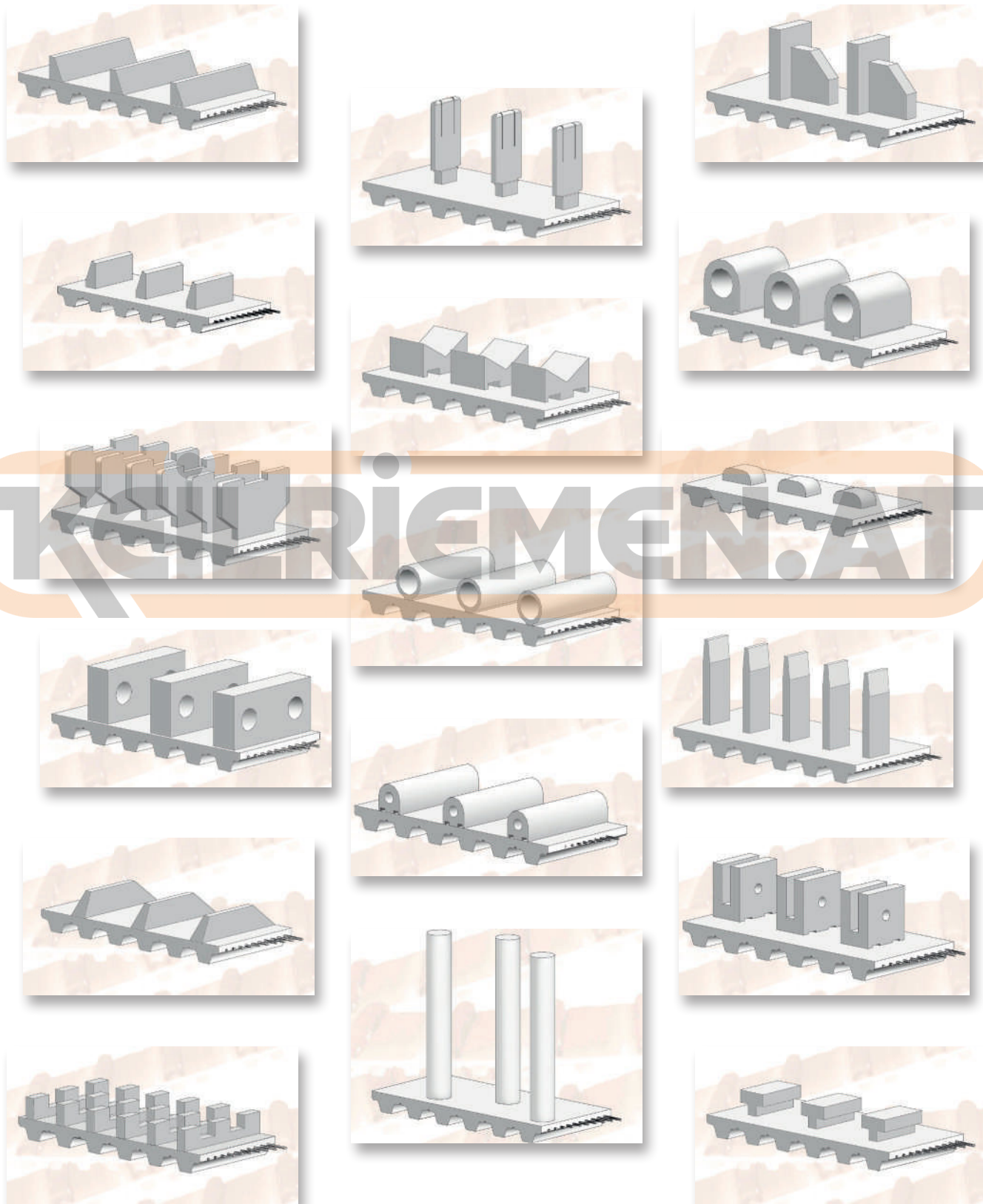

## FALSE TEETH

Megadyne has developed a new solution of mechanical profile application system specially designed for attaching cleats that cannot be welded onto polyurethane timing belts: FALSE TOOTH SYSTEM (FTS).

This mechanical mounting system for timing belts allows quick and easy exchange of individually designed cleats of different material (steel, urethane, UHMW, plastic, wood).

Now it is available a wide range of metallic false teeth with highly versatile and innovative system for attaching cleats in various positions, allowing synchronized feeding and product handling.

The belt can run smoothly around pulleys because the threaded inserts are embedded within the milled teeth.

### FTS ADVANTAGES INCLUDE:

- Easy exchange at any time.
- Can transmit much higher loads than welded profiles.
- Low cost in spare part in case of wear and tear.
- Reduction cost in assembly.
- Easy cleats fixing operation.
- Different cleat's material can be used.
- False tooth in stainless steel suitable for food & pharmaceutical industry.
- Not need to remove the belt in case of cleats replacement.
- High precision on profile positioning.
- Available on MEGALINEAR JOINED, MEGAFLEX and MEGAPOWER in all possible executions as NFT or NFB, FDA, steel, aramid or stainless steel cord, with or without self-tracking guide.



**PPJ SYSTEM**

### Technical features

- Reduced load capacity when compared to standard joined belts
- Created to allow the jointing of belts directly on the machine
- Allows a very fast belt replacement
- The back of the belts is virtually flat
- Born for conveying applications only, max suggested speed is 120 m/min
- Pin materials according to AISI302
- Rolls with NFT, NFB, AVAFC, APL, Fishbone, Ribbed and Supergrip can be PPJed
- Minimum splice length of 700 mm

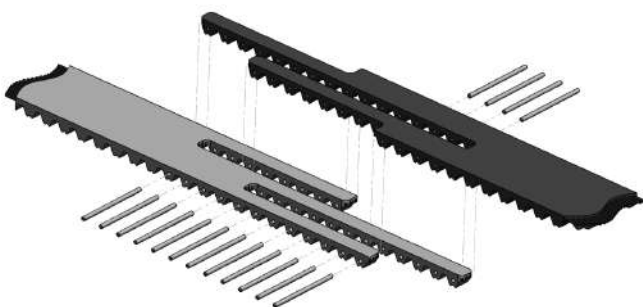

**STOP to maintenance shutdowns**

SECTION	Width* (mm)	Length* (mm)
T10 25	25	180
T10 32	32	220
T10 50	50	220
T10 75	75	240
T10 100	100	320
T20 32	32	260
T20 50	50	320
T20 75	75	340
AT10 25	25	180
AT10 32	32	220
AT10 50	50	220
AT10 75	75	240
AT10 100	100	320
AT20 32	32	260
AT20 50	50	320
AT20 75	75	340
MTD8 20	20	128
MTD8 30	30	176
MTD8 50	50	176
MTD8 85	85	192
MTD8 100	100	256
RPP8 20	20	128
RPP8 30	30	176
RPP8 50	50	176
RPP8 85	85	192
RPP8 100	100	256
TG10 50	50	220
ATG10 50	50	220

\*For different withs and/or lengths please contact us

## SPECIAL MODIFICATIONS

Megadyne can make special extrusions on customer request to enhance specific belt properties and to better suit special applications.

Process enhancements, skilled personnel, a can-do attitude and ongoing capital equipment investments enable Megadyne to stay at the forefront of new design developments and solution delivery to customers across the spectrum of industries we serve. Let a Megadyne Technical Sales and Application Engineer create the right belt to deliver optimum performance for your application.

### PROFILES GROUND IN COVER

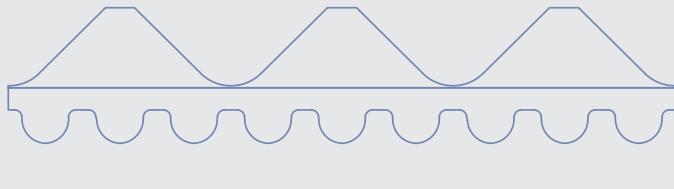

### LUG GRIND



### CONVEX GRIND



### DIAGONAL GROOVES

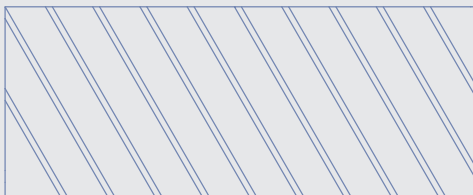

### SLOTS WITH HOLES

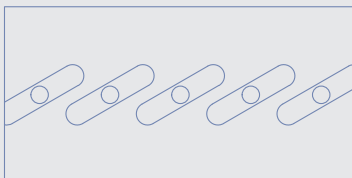

### COUNTERSINKS WITH HOLES



### PROFILES GROUND IN COVER

A belt back can be ground to achieve a precise belt thickness as an adjunct to precision drives. When belt back grinding to a tolerance is required, the total thickness, including the tooth, must be specified.

### LONGITUDINAL REWORK

Longitudinal rework along the belt back is possible on covered and uncovered belts. The profile can be machined precisely for required function. The measurement is given as the depth on the belt back. Most widths and lengths are available.

### HOLES IN TIMING BELTS

Holes in timing belts can be for vacuum or air film conveying or as clearance for assembly mechanisms. Stops and cams can be attached through the holes. Customized tooling may be required depending on the layout and dimensions of holes required.

