

V-BELTS

Rubber V-belts



MEGADYNE

INTRODUCTION TO V-BELTS



Megadyne V-belts have been used for decades in the most different industries and applications, offering drive solutions to customers all over the world.

Applied technology guarantees such a dimensional precision in V-belts which allows them to be suitable for multiple transmissions. This dimensional stability continues also during belt use.

The variety of belt sizes available allows the application of Megadyne V-belt in a wide range of drive applications, such as:

- machine tools
- industrial washing machines
- textile machines
- continuous paper machines
- high power mills
- stone crushers

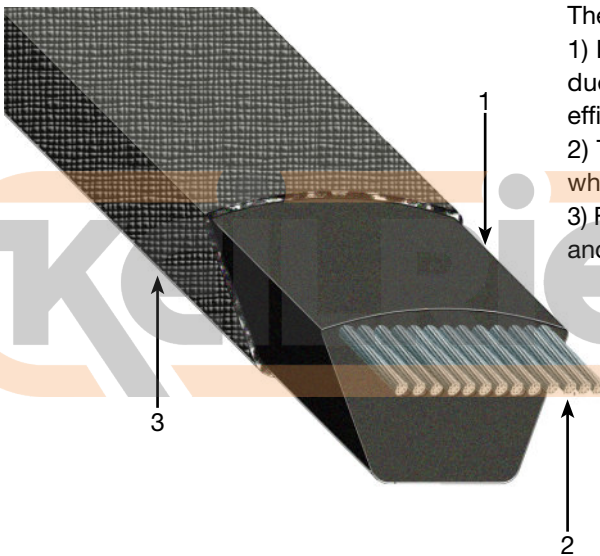

The main V-belt components are:

- 1) Belt body made of a special rubber compound which provides, due to its excellent mechanical characteristics, high transmission efficiency and assures a minimum rubber wear off;
- 2) Tensile member consisting in high-strength low-stretch cords, which grant length stability over the belt life time;
- 3) Fabric jacket or cover made of fabric, protecting the tensile member and permitting the use of back side idler.

MECHANICAL AND CHEMICAL FEATURES

- smooth starting and running
- wide range of driven speed
- low maintenance
- high efficiency
- extremely wide horsepower ranges
- dampen vibration between driver and driven pulleys
- silent operations
- long life service
- easy installation
- reduction in drive dimension
- working temperature range from -30°C to $+80/90^{\circ}\text{C}$ (see details in family pages)
- oil and heat resistance
- antistatic properties

MEGAMATCH **MEGA MATCH**

All V-belts carrying the MEGA MATCH logo are made and supplied according to the matching set tolerances and limits indicated by the relevant international standards (ISO, RMA, etc)

INTRODUCTION TO V-BELTS

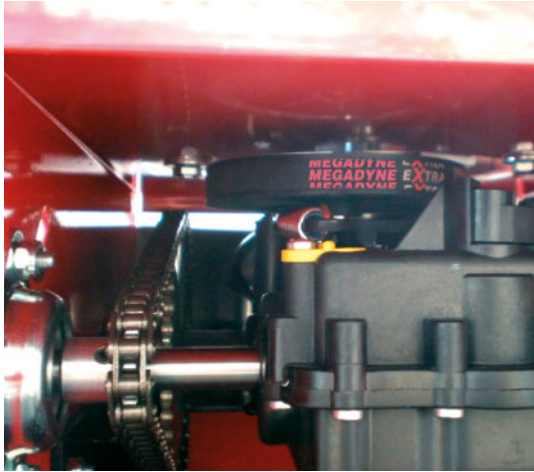

WRAPPED BELTS

EXTRA

Extra belts were designed to offer durable and reliable performances on light and medium-duty drives. They represent an affordable solution for transmission systems of all industrial sectors.

OLEOSTATIC

Oleostatic rubber belts are developed with high resistant tensile elements, they are characterised by high performances, length stability during belts life, conductivity, oil and heat resistance. They are particularly suitable for centrifugal pumps, compressor, tool machines, generators, high power mills and stone mills.

OLEOSTATIC GOLD

Different materials and design features, together with an improved production process, have led to the development of a new class of higher rated wrapped V-belts. The new OLEOSTATIC GOLD V-belts products family can operate in a wide range of industrial applications, within a large spread of load capacities and speeds — offering rated performance from 100 to 8,000 RPM and power capability from 1 to 400 kW, meanwhile granting large cost advantages for the end users.



Oleostatic Gold structure:

- 1) FABRIC: Double cover ply - CR Dip.

A reinforced, double fabric cover is plied around the belt to protect it against contamination and moisture. Its increased flexibility allows the belt to bend more easily around the smallest pulleys with far less strain on the fabric, while assuring a smoother running drive.

- 2) TOP CUSHION: SBR compound + Fibers
- 3) TENSILE CORD: H.T. Polyester

The tensile section is made up of a multiple number of high-strength, low elongation polyester cords, completely embedded in the adhesion layers, to enhance resistance to tension and flex-fatigue. Each cord is individually and specially coated to secure a long-lasting bond with the surrounding rubber and to grant a longer operational lifetime. In addition the belt requires significantly less retensioning and take-up due to its cord's consistent length stability. Longer belt life means less frequent replacement, less downtime and lower maintenance costs.

- 4) BOTTOM CUSHION: SBR compound + Fibers
- 5) BODY COMPOUND: Polychloroprene (CR) based

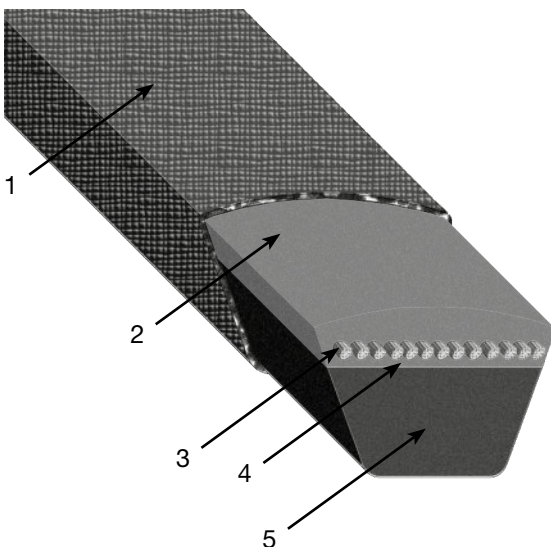

INTRODUCTION TO V-BELTS

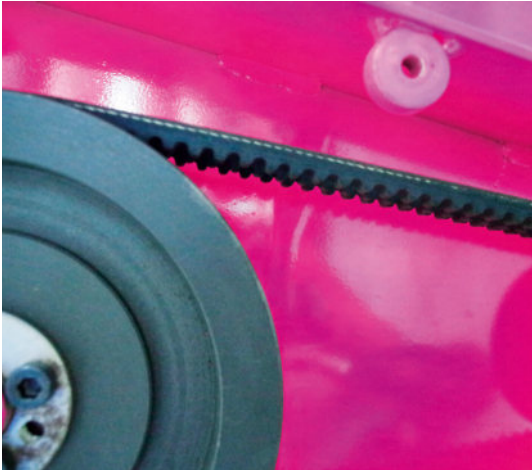

RAW EDGE

LINEA-X

These belts have been specifically developed to run where small pulleys diameters and high transmission ratios put a limit to the use of wrapped belts of the same section.

Compared to wrapped belts, the LINEA-X family offers important improvements, like specific compounds and special production technology. In particular the transverse orientation of the fibers improves the cord support capacity of the body section and reinforces its transverse rigidity, while maintaining, (due to the cogged profile and the precision-ground sidewalls) the highest longitudinal flexibility and running stability. These characteristics guarantee an excellent structure with advantages such as: high transmission ratios, improved grip and resistance to continuous bending.

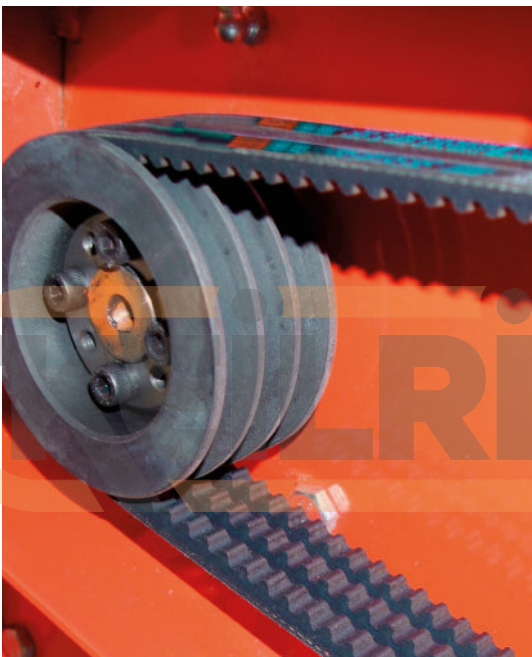

LINEA GOLD

The NEW generation of raw edge belts

New materials, advanced design features and an innovative production process has led MEGADYNE to develop a new generation of raw edge V-belt drives that outperform, in a wide range of industrial applications, all the previous drives equipped with standard raw edge belts, granting large cost advantages for the end users and greater design flexibility for the engineers. The belt has a narrow cross section and a raw edge construction, based on a new EPDM rubber compound which can withstand chemically aggressive environments, ageing, ozone, UV and heat.

Linea Gold structure:

1) BACKSIDE FABRIC

A textile fabric is plied on the belt backside to protect it against contamination and moisture.

Its flexibility gives the belt excellent reversed bending properties when backside idlers are used and protects the belt against wear.

2) ADHESION LAYERS

An innovative, colored, EPDM compound located immediately above and below the belt cords, guarantees the best possible bonding with the under cord body material.

3) TENSILE CORD

The tensile section is made up of a multiple number of high-strength, low elongation polyester tensile cords which are completely embedded in the adhesion layers and vulcanized as one solid unit to enhance resistance to tensile and flex-fatigue forces. On request, for special extreme requirements, aramid or glassfibre cords are also available.

4) BODY COMPOUND

A newly developed EPDM compound, with high-performance fibers embodied in the rubber matrix, provides to the belt with superior abrasion and wear resistance. The transversal orientation of the fibers improves the cord support capacity of the body section and reinforces its transversal rigidity, while maintaining, in connection with the cogged profile and the precision-ground sidewalls, the utmost longitudinal flexibility and running stability.

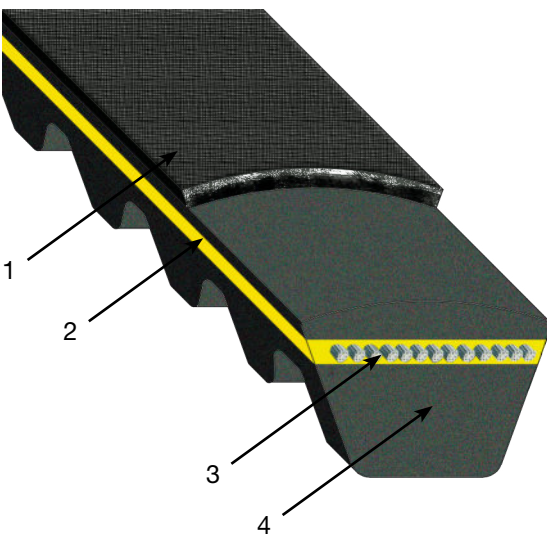



SECTIONS

- Z E
- A 20
- B 25
- C 45
- D 50

Classical wrapped V-belts

(Extra - Oleostatic - Oleostatic Gold)

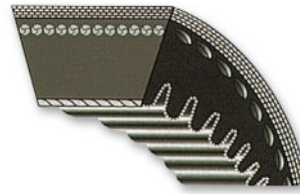

SECTIONS

- AX
- BX
- CX

Classical raw edge V-belts

(Linea Gold)



SECTIONS

- SPZ
- SPA
- SPB
- SPC

Narrow wrapped V-belts DIN

(Extra - Oleostatic Gold)



SECTIONS

- XPZ
- XPA
- XPB
- XPC

Narrow raw edge V-belts DIN

(Linea-X - Linea Gold)



SECTIONS

- 3V
- 5V
- 8V

Narrow wrapped V-belts RMA

(Oleostatic)



SECTIONS

- | | |
|-------|-------|
| 13x6 | 36x12 |
| 17x6 | 37x10 |
| 21x7 | 42x13 |
| 22x8 | 47x13 |
| 26x8 | 52x16 |
| 28x8 | 55x16 |
| 30x10 | 65x20 |
| 32x10 | 70x20 |

Variable speed V-belts

(Varisect)



SECTIONS

- XDV2-38
- XDV2-48
- XDV2-58

Xtra Duty V-belts

(XDV2)



SECTIONS

- AA
- BB
- CC

Double V-belts

(Esaflex)



SECTIONS

- | | |
|------|------|
| RA | RSPC |
| RB | R3V |
| RC | R5V |
| RSPZ | R8V |
| RSPA | R3VX |
| RSPB | R5VX |

Banded V-belts

(Pluriband)

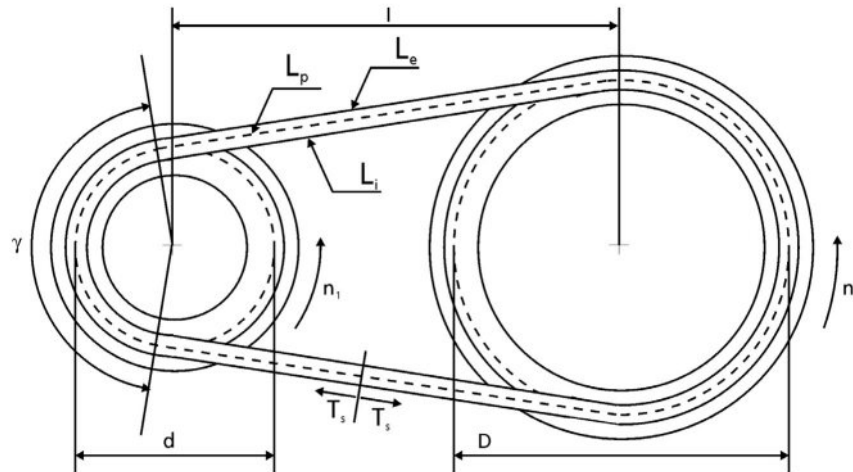

Symbol	Unit	Definition	Symbol	Unit	Definition
C_γ		correction factor C_γ	L_p	mm	pitch length (effective)
C_L		correction factor C_L	n_1	RPM	speed of smaller pulley (faster)
C_c		correction factor C_c	n_2	RPM	speed of bigger pulley (slower)
d	mm	pitch diameter of smaller pulley	P	kW	power to be transmitted
D	mm	pitch diameter of bigger pulley	P_a	kW	actual power of the transmission
I	mm	theoretical center distance	P_b	kW	basic performance of a single belt
I_e	mm	effective center distance	P_c	kW	corrected power
i		transmission ratio	P_d	kW	difference to P_b due to $K \neq 1$
L'	mm	calculated pitch length	Q		number of belts
L_e	mm	external length ($L_p + \Delta$)	T_s	N	static belt tension
L_i	mm	internal length ($L_p - \Delta$)	v	m/s	peripheral belt speed
			γ	°	arc of contact

BELT SECTION

Necessary data for selection of the belt section:

P = power to be transmitted in kW

n_1 = speed in RPM of the smaller pulley

n_2 = speed in RPM of the bigger pulley

It is necessary to correct the power P by a coefficient C_c (see table 1 page 6) which considers into account the actual operating conditions.

Corrected power P_c is given by:

$$P_c = P \cdot C_c$$

The graphs gives a guiding criterion for the section of the belt.

TRANSMISSION RATIO

Transmission ratio is calculated as follows:

$$i = \frac{n_1}{n_2} = \frac{D}{d}$$

where D is the pitch diameter of larger pulley and d is the pitch diameter of the smaller pulley.

TECHNICAL CALCULATION

Peripheral speed of the belts is determined by

$$v = \frac{d \cdot n_1}{19100}$$

If the drive being calculated is of the V/flat type (one V pulley and one flat pulley) it is necessary to find the corresponding pitch diameter of the flat pulley.

The pitch diameter of the flat faced pulley is obtained by increasing its external diameter by the amount in millimetres shown in the following table:

Z	A	B	C	D	E	19	20	25
8	10	14	20	24	33	16	15	19

PITCH LENGTH OF THE BELT AND CORRECT CENTER DISTANCE

Whenever the shaft center distance l is not predetermined by the layout of the drive, the optimum distance may be chosen as follows:

$$1 < i < 3 \quad l \geq \frac{(i+1) \cdot d}{2} + d$$

$$i > 3 \quad l \geq D$$

The pitch length is determined by:

$$L' = 2 \cdot l + 1,57 \cdot (D+d) + \frac{(D-d)^2}{4l}$$

From the list of belt sizes, should be selected the belt pitch length L_p nearest to the value of L' above calculated. Since $L' \neq L_p$ the center distance " l " may be varied by subtracting half $L' - L_p$. Therefore the effective center distance of the drive will be:

$$l_e = l - \frac{(L' - L_p)}{2}$$

NUMBER OF BELTS

The basic performance P_b is the power which a single belt transmits under the following conditions:

- $i = 1$

This configuration corresponds to 180° arc of contact belt on both pulleys;

- $i \neq 1$

The difference of kW-rating P_d is the power which the belt transmits in excess of P_b because $i \neq 1$ in service conditions. The actual kW-rating P_a is the power which the belt transmits in operating conditions and is obtained by means of:

$$P_a = (P_b + P_d) \times C_g \times C_L$$

Table 4 (see belt family pages) gives the values of P_b according to RPM and d (smaller diameter) and the values of P_d according to RPM and i .

Table 2 (bottom of this page) and 3 (see belt family pages) give values of the coefficients C_γ and C_L taking into account the operating conditions.

The arc of contact γ of the belt on the smaller pulley is determined by:

$$\gamma = 180^\circ - 57 \cdot \frac{D-d}{l_e}$$

The number of belts Q necessary for the transmission of the power P_c is determined by:

$$Q = \frac{P_c}{P_a}$$

The number of belts actually is obtained in general by rounding up Q to the next highest whole number.

TABLE 1 - TYPE OF MOTOR

Applications	Drivers					
	(1)			(2)		
	Daily operating hours					
	0-8 ⁽¹⁾	8-16 ⁽¹⁾	16-24 ⁽¹⁾	0-8 ⁽²⁾	8-16 ⁽²⁾	16-24 ⁽²⁾
Light use Centrifugal pumps and compressors, belt conveyors, (light materials) fans and pumps up to 7,5 kW.	1,1	1,1	1,2	1,1	1,2	1,3
Normal use Shears for steel sheet presses, belt and chain conveyors, (heavy material) sifters, generator sets, machine tools, kneading machines, industrial washing machines, printing presses, fans and pumps over 7,5 kW.	1,1	1,2	1,3	1,2	1,3	1,4
Heavy use Hammer mills, piston compressors, belt conveyors for heavy loads, lifters, textile machines, continuous paper machines, piston and dredging pumps, ripping saws.	1,2	1,3	1,4	1,4	1,5	1,6
Extra heavy use High power mills, stone crushers, calendars, mixer, cranes, diggers, dredgers.	1,3	1,4	1,5	1,5	1,6	1,8

TABLE 2 - Correction factor C_γ (T/T=V/V drives; T/P=V/Flat drives; γ =arc of contact on the smaller pulley)

γ	180°	175°	170°	165°	160°	155°	150°	145°	140°	135°	130°	125°	120°	115°	110°	105°	100°	90°	
C_γ	T/T	1	0,99	0,98	0,96	0,95	0,93	0,92	0,90	0,89	0,87	0,86	0,84	0,82	0,80	0,78	0,76	0,74	0,69
	T/P	0,75	0,76	0,77	0,79	0,80	0,81	0,82	0,83	0,84	0,85	0,86	0,84	0,82	0,80	0,78	0,76	0,74	0,69

WRAPPED V-BELTS SELECTION CHARTS

Classical wrapped V-belts

EXTRA

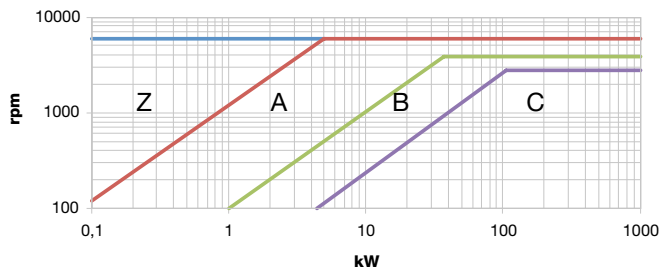

Narrow wrapped V-belts DIN

EXTRA

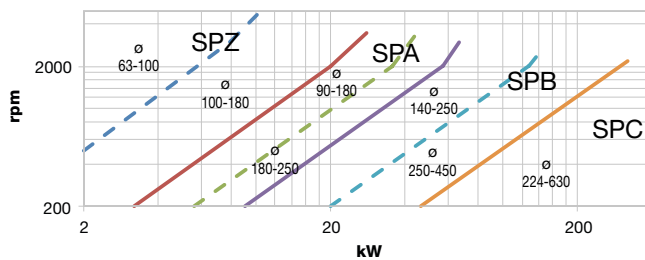

OLEOSTATIC GOLD

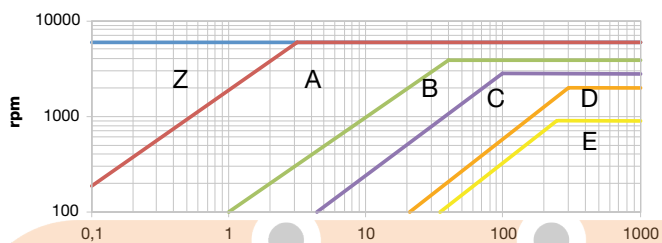

OLEOSTATIC GOLD

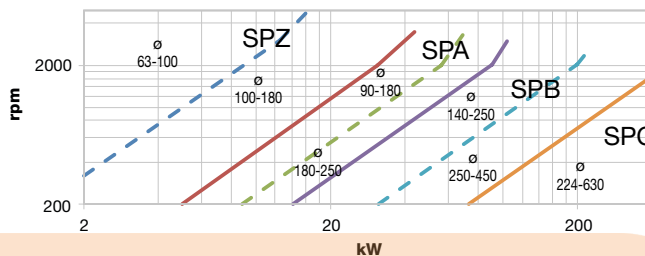

Narrow wrapped V-belts RMA

OLEOSTATIC

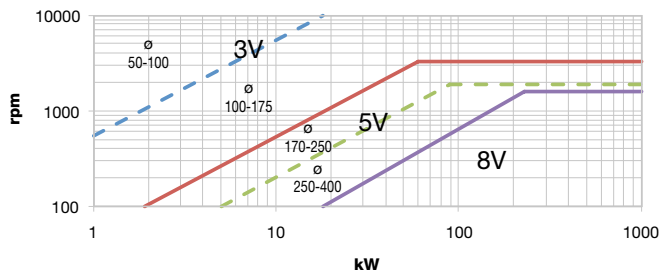

RAW EDGE V-BELTS SELECTION CHARTS

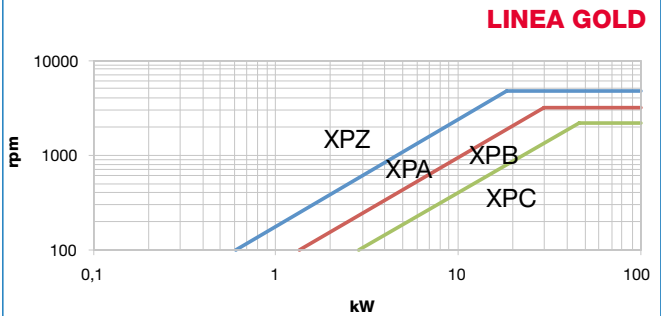
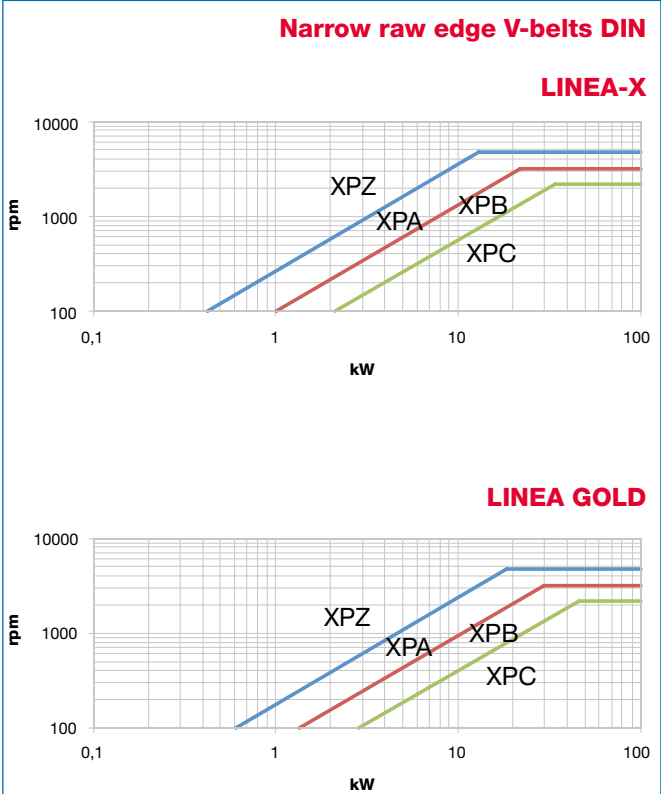
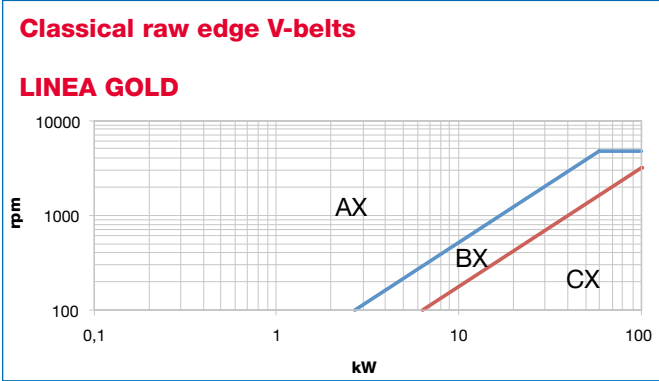

CALCULATION EXAMPLE

EXAMPLE

$P = 22 \text{ kW}$

$n_1 = 1200 \text{ RPM}$

$n_2 = 660 \text{ RPM}$

Textile machine operating 12 hours a day

Type of motor: ac electric motor, normal torque

The correction coefficient is 1,3 (see table 1)

The corrected power is:

$$P_c = 22 \cdot 1,3 = 28,6 \text{ kW}$$

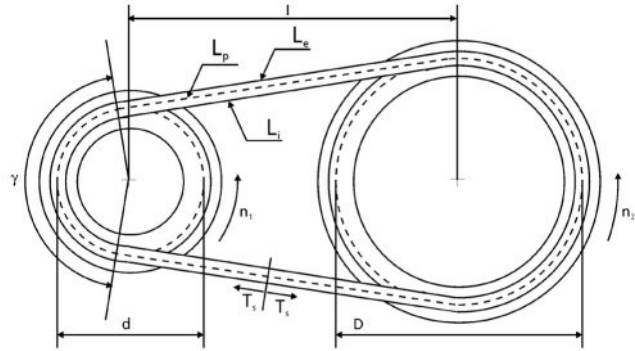

BELT SELECTION

From selection charts, for $P_c = 28,6$ and $n_1 = 1200 \text{ RPM}$ it is appropriate to choose section B.

TRANSMISSION RATIO

The transmission ratio can be calculated as follows:

$$i = \frac{n_1}{n_2} = \frac{1200}{660} = 1,82$$

Considering diameter $d = 250 \text{ mm}$ for the smaller pulley, the pitch diameter of the larger pulley is:

$$D = i \cdot d = 1,82 \cdot 250 = 455 \text{ mm}$$

Peripheral speed of the belts is determined by

$$v = \frac{d \cdot n_1}{19100}; v = \frac{0,052 \cdot 250 \cdot 1200}{19100} = 15,7 \text{ m/s}$$

BELT PITCH LENGTH AND CORRECT CENTER DISTANCE

For $i = 1,82$ (i.e. $1 < i < 3$) the center distance is given by:

$$l \geq \frac{(i+1) \cdot d}{4} + d \quad \text{so} \quad l = 610 \text{ mm}$$

The pitch length of the belt is determined by:

$$L' = 2 \cdot l + 1,57 \cdot (D+d) + \frac{(D-d)^2}{4 \cdot l};$$

$$L' = 2 \cdot 610 + 1,57 \cdot (455+250) + \frac{(455-250)^2}{4 \cdot 610} = 2344 \text{ mm}$$

From the list of belt sizes (see table on belt family pages), should be selected the belt pitch length L_p nearest to the value of L' previously calculated.

The center distance "l" may be varied by subtracting half $L' - L_p$. Therefore the effective centre distance of the drive will be:

$$l_e = l - \frac{L' - L_p}{2}$$

Having selected **Oleostatic Gold B 91** ($L_p = 2355 \text{ mm}$), the actual shaft center distance is calculated by:

$$l_e = 610 - \frac{2344 - 2355}{2} = 615,5 \text{ mm}$$

From table 4 of B section (d=250 mm; 1200 RPM; K=1,82):

$$P_b = 11,57 \text{ kW}$$

$$P_d = 0,48 \text{ kW}$$

The arc of contact γ of the belt on the smaller pulley is determined by:

$$\gamma = 180^\circ - 57 \cdot \frac{D-d}{l_e} = 180^\circ - 57 \cdot \frac{455-250}{616} \cong 161^\circ$$

From table 2 for $\gamma = 161^\circ$

$$C_\gamma = 0,95$$

From table 3, pag 19 for **Oleostatic Gold B 91** belt

$$C_L = 1,00$$

Therefore:

$$P_a = (11,57+0,48) \cdot 0,95 \cdot 1,00 = 11,45 \text{ kW}$$

The number of belts Q necessary for transmission of the power P_c is established by:

$$Q = \frac{P_c}{P_a} = \frac{28,6}{11,45} = 2,5$$

Round up to 3 belts **Oleostatic Gold B 91**.

BELT TENSIONING RECOMMENDATION

The correct belt assembling tension is given by:

$$T_s = 500 \cdot \frac{2,5 - C_\alpha}{C_\alpha} \cdot \frac{P_c}{Q \cdot v} + m \cdot v^2$$

Symbol	Unit	Definition
C_α		arc correction factor
m	kg/m	belt linear mass (see belt family page)
P_c	kW	corrected power
Q		number of belts
T_s	N/strand	static belt tension
v	m/s	peripheral belt speed
α	°	arc of contact

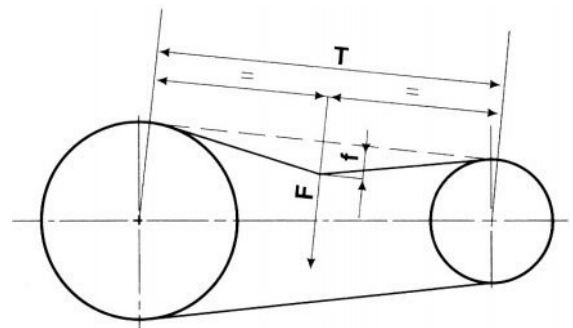

Arc correction factor:

α [°]	180	174	169	163	157	151	145	139	133	127	120	113	106	99	91	83
C_α	1,00	0,98	0,97	0,96	0,94	0,93	0,91	0,89	0,87	0,85	0,82	0,80	0,77	0,73	0,70	0,65

LENGTH MEASURING AND GROOVE PULLEYS

BELT LENGTH MEASURING

The first and easiest way for measuring the V-belt length is by placing the belt on a flat surface, giving the belt a circular shape and finally measuring the internal length L_i by means of a measuring tape. Adding Δ_i and after Δ_e (see belt families pages) to this length, it's possible to calculate respectively L_p and L_e .

This measuring way is not very precise, even if practically easy and feasible with a tape only.

The correct way for measuring the V-belt length is by means of pulleys and dynamometer. The belt is put on 2 pulleys, specific for the family and size of the belt and having the same pitch diameter. One is fixed while the second can move on a linear graduated scale. Depending on the belt, a certain force is applied to the second pulley in order to put the complete system under tension. The correct force is tabled the relevant standards referring to the belt family.

To stabilize the system, at least 3 rotations of the pulleys are required.

The pitch length L_p is given by the pulleys pitch diameter D and center distance a in the formula:

$$L_p = 2 a * \pi_D$$

Subtracting Δ_i and adding Δ_e (see belt families pages) it's possible to calculate respectively L_i and L_e .

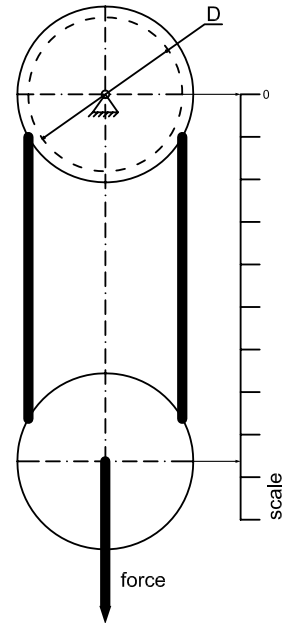

GROOVE PULLEYS

Groove pulleys for V-belts must be manufactured with care and be made of good quality steel or engineering cast iron. It is most important that the flanks of the grooves shall be perfectly smooth and show no visible sign of machining, that all sharp corners of the grooves shall be rounded off and chamfered and that the external diameter of the face shall be constant overall.

All pulleys must also be statically balanced.

Dynamic balancing is required for speeds over 30 m/second.

Profile and dimension of pulley should be in accordance to DIN 2211, BS 3790, ISO, RMA depending on the belt relevant standard.

In the drawing are shown the main characteristics and dimensions of groove pulleys for V-belts (example referring to Oleostatic belts).

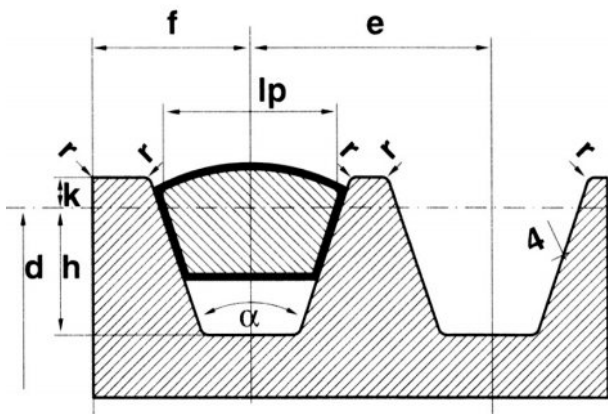

- lp** = pitch width
- k** = minimum height of groove above the pitch line
- h** = minimum depth of groove below the pitch line
- α** = groove angle
- d** = pitch diameter
- e** = distance between the axes of the sections of two grooves
- f** = distance between the axis of the section of the outer groove and the rim of the pulley

LENGTH MEASURING AND GROOVE PULLEYS

The use of idlers in V-belt drives is not recommended.

However, due to particular drive requirements and limitations, use of idlers may be absolutely necessary.

For using idlers, requirements are as follows:

1. Providing take-up for fixed center drives.
2. Turning corners (as in mule pulley drives).
3. Breaking up long spans where belt whip may be a problem.
4. Maintaining tension, when idler is spring-loaded or weighted.

A power correction (see below) is required.

OUTSIDE IDLER

1. An outside idler should be at least one and one-third times as large as the smallest pulley on the drive, unless drive has unusually large pulleys.
2. An outside idler must be flat and without any crown.
3. To find the face width of a flat idler (between flanges if flanged) add 1 ½ times the nominal belt top width to the face width of the grooved pulley used.
4. An outside idler pulley should be located as close as possible to the preceding pulley. This is because V-belts move back and forth slightly on a flat pulley and locating it as far away from the next pulley minimizes the possibility of the belt entering that pulley in a misaligned condition.
5. Idler pulleys should be located only on the slack side of a drive.

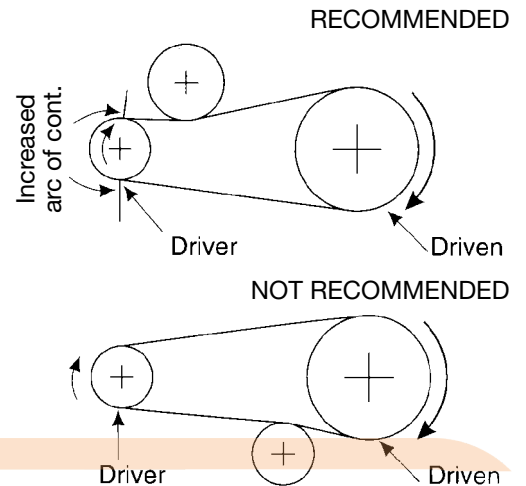

INSIDE IDLER

1. An inside idler will decrease the arc of contact.
2. An inside idler should be at least as large as the smallest pulley on the drive, unless the drive has unusually large pulleys.
3. An inside idler should better be a grooved pulley. In alternative, flat pulleys can be used.
4. A grooved inside idler pulley may be located anywhere along the span, preferably so that it gives nearly equal arcs of contact on the two adjacent pulleys.
5. Idler pulleys should be located only on the slack side of a drive.

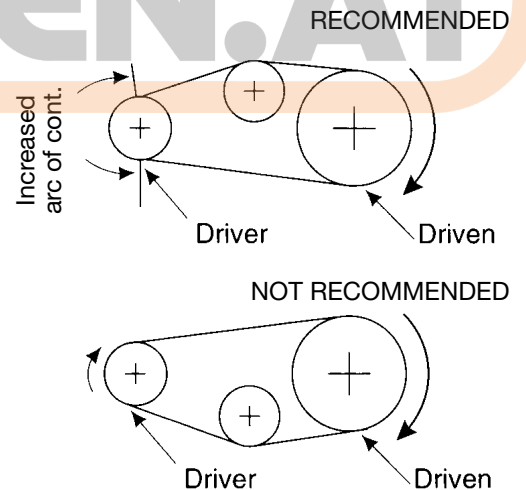

RATED POWER CORRECTION

Because idlers impose an additional bending stress point on the V-belt, the transmittable power is reduced.

The smaller the idler diameter, the greater the bending stress, which results in a greater reduction in rated power and belt life.

To compensate this loss, the design power of the drive must be increased.

The following table gives the approximate correction factors according to the number of pulleys in the drive.

The normal power rating should be multiplied by this factor.

No. of pulleys in drive	2	3 (one idler)	4 (two idlers)
Rating Correction Factor	1,00	0,90	0,80

Note:

As stated, the above listed factors are only approximate values and apply only when idler diameters and their location is in accordance with the above recommendations.

STORAGE MAINTENANCE AND USEFUL ADVICES

HOW TO STORE BELTS

In order to store V-Belts correctly, it is advisable to hang them on “saddles” or on large-diameter tubular brackets. This diameter should be at least ten times the height of belts cross section.

Long belts can be stacked to save space, provided that they are correctly coiled (see figures).

Short belts can be stored on shelves, but be aware that stacks should not be more than 300 mm high, as the bottom belts may be otherwise deformed.

Finally, hooks and nails are unsuitable for suspending the belts.

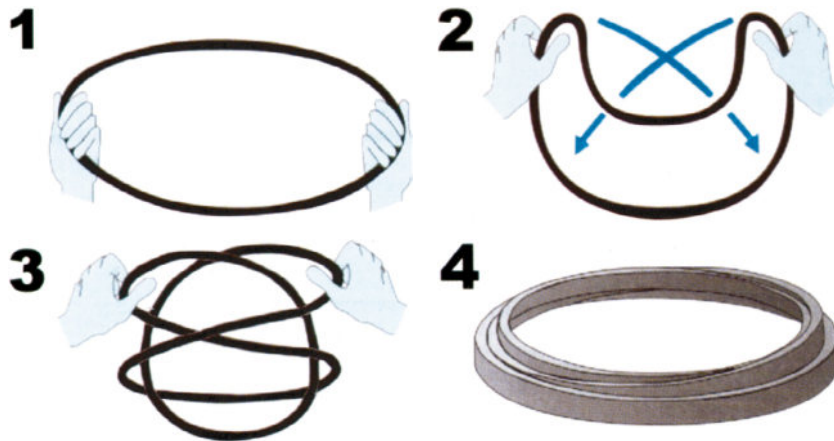

CONDITIONS OF STORAGE

Rubber V-belts can be stored for several years without causing any performance or reliability loss.

For a correct storage, some prescription have to be taken into account.

- Environment

The storage premises should be cool, dry and well ventilated but not draughty.

- Temperature

Storage temperature should be within +5 and +30°C.

Lower temperatures causes stiffening in the belt but are accepted in the storage. In order to avoid damages in the start-up, it becomes necessary to heat the belt up to around 20° before making it run on the machine.

Higher temperatures due to heating are to be avoided. Distance from heating sources should be at least 1 meter.

- Light

Belts should be protected from light, especially direct sunlight and artificial light with high ultraviolet rays (neon light).

- Ozone

Equipments generating ozone, like high voltage electrical machines or fluorescent light sources, should not be installed in the storage.

Also combustion gases and vapours, that can cause ozone, should be avoided.

- Chemicals

Flammable materials, lubricants, acids and any other aggressive material should not be kept in the storage. Belts elastomers may be affected or even irreparably damaged by such agents.

CLEANING

Never clean V-belts. If you need, for any reason, to clean belts use a dry towel or one soaked with a glycerine/alcohol mixture in the ratio 1:10. Other solvents such as petrol or benzene must not be used.

Sharp-edged objects must not be used for cleaning V-belts.

To ensure a long service life and high performances, it is important to design correctly the application and to take care of correct installation, maintenance and storage of the belt.

A drive must be designed in such a way to make proper provision for both installation and tensioning of the V-belts. For this purpose a take-up device is necessary; a slide adjuster on the motor is recommended to simplify installation and permit optimum tensioning.

Table 5 (see belt family pages) provides minimum variation of center distance permitted for installation and tensioning of the belts.

x	=	Take up allowance
y	=	Installation allowance
l	=	Center distance

Furthermore, the following rules must always be observed:

- 1) check the alignment of the drive pulleys;
- 2) make sure that the flanks of the grooves are clean;
- 3) adjust the tensioner to stretch the belts sufficiently;
- 4) check the tension (see following section);
- 5) check correct diameter for tensioning pulley;
- 6) protect belt from oil and other chemicals;
- 7) when installing belts, slack off tensioner and avoid using tools or implements which may damage the belts.

Pulleys with large diameters increase belt life. They must be statically balanced up to the speed of 30 m/s and dynamically balanced over this value.

TENSIONING SYSTEM

The satisfactory performance of a transmission equipped with V-belts depends on the correct fitting tension. It is therefore necessary to proceed in the following way, using the slide adjuster:

Belt tension control by deflection method

The approximate relation among deflection force, belt deflection and belt tension is given by:

$$T_s \approx \frac{f \cdot t}{4 \cdot f}$$

Imposing a belt deflection

$$f = \frac{t}{64}$$

the deflection force should be in the range

$$F_{\min} \approx F' = \frac{T_s}{16} \quad F_{\max} \approx F'' = \frac{1,5 \cdot T_s}{16}$$

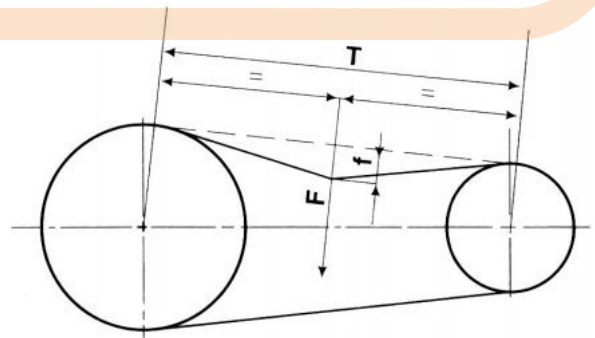

where:

Symbol	Unit	Definition
F	N	perpendicular deflection force
f	mm	belt deflection
t	mm	free span length
T_s	N/strand	static belt tension (see page 9)

Belt tension control by vibration method

$$\text{Belt vibration frequency: } F_r^2 = \frac{T_s}{4 \cdot m \cdot t^2}$$

Symbol	Unit	Definition
F_r	Hz	natural frequency of belt
m	kg/m	specific belt mass
t	m	free span length
T_s	N/strand	static belt tension (see page 9)

NARROW WRAPPED V-BELTS DIN

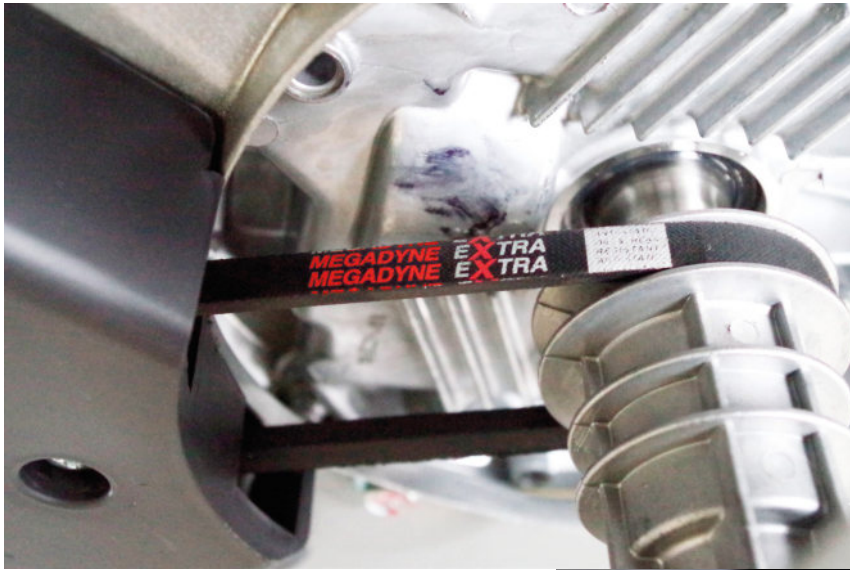

NARROW WRAPPED V-BELTS DIN Extra - Oleostatic Gold

BELT CHARACTERISTICS

section	SPZ	SPA	SPB	SPC
a (mm)	9,7	12,7	16,3	22
s (mm)	8	10	13	18
pitch length - internal length = Δi (mm)	39	47	61	86
external length - pitch length = Δe (mm)	13	18	22	30
weight (gr/m)	70	120	195	365
min. pulley diam. (mm)	63	90	140	224
working temperature	-30°C / +80°C			
relevant standards	DIN 7753 - ISO 4184			
relevant antistatic standard	ISO 1813			
materials	SBR and/or CR blend - polyester cord - cotton/polyester fabric			

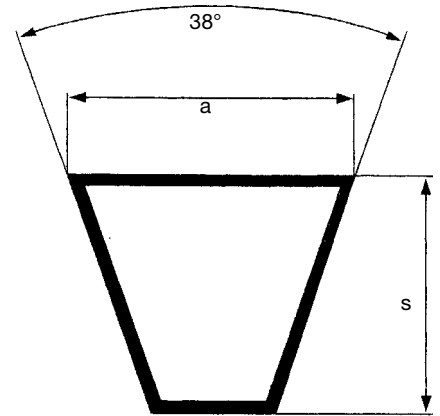

TABLE 3 - CORRECTION FACTOR C_L according to type and length of the belt

	512	630	710	732	800	900	1000	1120	1250	1400	1600	1800	2000	2240	2500	2800	3150	3550	4000	4500	5000	5600	6300	7100	8000	9000	10000	11200	12500	
SPZ	0,81	0,82	0,84	0,85	0,86	0,88	0,90	0,93	0,94	0,96	1,00	1,01	1,02	1,05	1,07	1,09	1,11	1,13												
SPA			0,80	0,81	0,83	0,85	0,87		0,89	0,91	0,93	0,95	0,96	0,98	1,00	1,02	1,04	1,06	1,08	1,09										
SPB									0,82	0,84	0,86	0,88	0,90	0,92	0,94	0,96	0,98	1,00	1,02	1,04	1,06	1,08	1,10	1,12	1,14					
SPC													0,81	0,83	0,86	0,88	0,90	0,92	0,94	0,96	0,98	1,00	1,02	1,04	1,06	1,08	1,10	1,12	1,14	

TABLE 5 - INSTALLATION AND TAKE UP ALLOWANCE

L (mm)	Y (mm)				X (mm)
	SPZ	SPA	SPB	SPC	
512 / 670	15	15			10
670 / 1000	15	20			14
1000 / 1250	20	20			18
1250 / 1800	20	25	30		23
1800 / 2240	25	25	30	40	28
2240 / 3000	25	30	35	45	36
3000 / 3500	30	30	40	45	44

NARROW WRAPPED V-BELTS DIN



Extra SPZ SECTION

Code	External length LE (mm)	Code	External length LE (mm)	Code	External length LE (mm)	Code	External length LE (mm)	Code	External length LE (mm)	Code	External length LE (mm)	Code	External length LE (mm)
SPZ 487	500	SPZ 812	825	SPZ 1024	1037	SPZ 1250	1263	SPZ 1512	1525	SPZ 1850	1863	SPZ 2262	2275
SPZ 512	525	SPZ 825	838	SPZ 1037	1050	SPZ 1262	1275	SPZ 1520	1533	SPZ 1862	1875	SPZ 2287	2300
SPZ 562	575	SPZ 837	850	SPZ 1047	1060	SPZ 1270	1283	SPZ 1537	1550	SPZ 1887	1900	SPZ 2360	2373
SPZ 587	600	SPZ 850	863	SPZ 1060	1073	SPZ 1287	1300	SPZ 1562	1575	SPZ 1900	1913	SPZ 2410	2423
SPZ 607	620	SPZ 862	875	SPZ 1077	1090	SPZ 1312	1325	SPZ 1587	1600	SPZ 1937	1950	SPZ 2437	2450
SPZ 612	625	SPZ 875	888	SPZ 1087	1100	SPZ 1320	1333	SPZ 1600	1613	SPZ 1962	1975	SPZ 2487	2500
SPZ 630	643	SPZ 887	900	SPZ 1112	1125	SPZ 1337	1350	SPZ 1612	1625	SPZ 1987	2000	SPZ 2500	2513
SPZ 637	650	SPZ 900	913	SPZ 1120	1133	SPZ 1340	1353	SPZ 1637	1650	SPZ 2000	2013	SPZ 2540	2553
SPZ 662	675	SPZ 912	925	SPZ 1137	1150	SPZ 1347	1360	SPZ 1650	1663	SPZ 2019	2032	SPZ 2650	2663
SPZ 670	683	SPZ 922	935	SPZ 1140	1153	SPZ 1362	1375	SPZ 1662	1675	SPZ 2030	2043	SPZ 2690	2703
SPZ 687	700	SPZ 925	938	SPZ 1147	1160	SPZ 1387	1400	SPZ 1687	1700	SPZ 2037	2050	SPZ 2800	2813
SPZ 710	723	SPZ 937	950	SPZ 1150	1163	SPZ 1400	1413	SPZ 1700	1713	SPZ 2062	2075	SPZ 2840	2853
SPZ 722	735	SPZ 950	963	SPZ 1162	1175	SPZ 1412	1425	SPZ 1737	1750	SPZ 2087	2100	SPZ 3000	3013
SPZ 737	750	SPZ 962	975	SPZ 1180	1193	SPZ 1420	1433	SPZ 1750	1763	SPZ 2120	2133	SPZ 3150	3163
SPZ 750	763	SPZ 975	988	SPZ 1187	1200	SPZ 1437	1450	SPZ 1762	1775	SPZ 2137	2150	SPZ 3350	3363
SPZ 762	775	SPZ 987	1000	SPZ 1200	1213	SPZ 1462	1475	SPZ 1787	1800	SPZ 2150	2163	SPZ 3550	3563
SPZ 772	785	SPZ 1000	1013	SPZ 1202	1215	SPZ 1470	1483	SPZ 1800	1813	SPZ 2160	2173		
SPZ 787	800	SPZ 1010	1023	SPZ 1212	1225	SPZ 1487	1500	SPZ 1812	1825	SPZ 2187	2200		
SPZ 800	813	SPZ 1012	1025	SPZ 1237	1250	SPZ 1500	1513	SPZ 1837	1850	SPZ 2240	2253		

TABLE 4 - P_b (kW) referred to Ø (mm)

P_d (kW) referred to i

RPM / Ø	63	71	80	90	100	112	125	140	150	160	170	180	RPM / i	1,00/1,01	1,02/1,05	1,06/1,11	1,12/1,18	1,19/1,26	1,27/1,38	1,39/1,57	1,58/1,94	1,95/3,38	over 3,38
100	0,08	0,10	0,13	0,16	0,18	0,22	0,25	0,30	0,32	0,35	0,38	0,41	100	0,00	0,00	0,00	0,01	0,01	0,01	0,01	0,01	0,01	0,01
200	0,14	0,19	0,24	0,29	0,34	0,41	0,48	0,56	0,61	0,66	0,71	0,77	200	0,00	0,00	0,01	0,01	0,01	0,02	0,02	0,02	0,02	0,03
500	0,30	0,41	0,52	0,65	0,78	0,93	1,09	1,27	1,40	1,52	1,64	1,76	500	0,00	0,01	0,01	0,03	0,04	0,04	0,05	0,06	0,06	0,07
700	0,40	0,54	0,70	0,87	1,04	1,25	1,47	1,72	1,89	2,05	2,21	2,38	700	0,00	0,01	0,02	0,04	0,05	0,06	0,07	0,08	0,09	0,09
900	0,48	0,66	0,86	1,08	1,30	1,55	1,83	2,15	2,35	2,56	2,77	2,97	900	0,00	0,01	0,03	0,05	0,06	0,08	0,09	0,10	0,11	0,12
1.000	0,52	0,72	0,94	1,18	1,42	1,70	2,01	2,35	2,58	2,81	3,03	3,26	1.000	0,00	0,01	0,03	0,05	0,07	0,09	0,10	0,11	0,12	0,13
1.400	0,68	0,94	1,24	1,57	1,89	2,27	2,68	3,15	3,45	3,75	4,05	4,35	1.400	0,00	0,02	0,04	0,07	0,10	0,12	0,14	0,16	0,17	0,18
1.500	0,71	1,00	1,31	1,66	2,00	2,41	2,85	3,34	3,66	3,98	4,29	4,60	1.500	0,00	0,02	0,04	0,08	0,11	0,13	0,15	0,17	0,18	0,20
1.700	0,78	1,10	1,45	1,84	2,23	2,68	3,16	3,71	4,06	4,41	4,76	5,10	1.700	0,00	0,02	0,05	0,09	0,12	0,15	0,17	0,19	0,21	0,22
1.800	0,81	1,15	1,52	1,93	2,33	2,81	3,31	3,88	4,26	4,62	4,98	5,34	1.800	0,00	0,02	0,05	0,09	0,13	0,15	0,18	0,20	0,22	0,23
2.500	1,02	1,47	1,96	2,50	3,03	3,65	4,30	5,03	5,50	5,95	6,39	6,82	2.500	0,00	0,03	0,07	0,13	0,18	0,21	0,25	0,28	0,31	0,33
2.900	1,12	1,63	2,19	2,80	3,39	4,08	4,80	5,60	6,10	6,59	7,05	7,49	2.900	0,00	0,03	0,09	0,15	0,21	0,25	0,29	0,33	0,36	0,38
3.000	1,15	1,67	2,25	2,87	3,48	4,19	4,92	5,73	6,24	6,73	7,20	7,64	3.000	0,00	0,03	0,09	0,16	0,21	0,26	0,30	0,34	0,37	0,39
3.400	1,23	1,81	2,45	3,14	3,80	4,57	5,35	6,20	6,73	7,24	7,70	8,14*	3.400	0,00	0,04	0,10	0,18	0,24	0,29	0,34	0,38	0,42	0,44
3.600	1,27	1,88	2,54	3,26	3,95	4,74	5,55	6,41	6,95	7,45	7,91*	8,33*	3.600	0,00	0,04	0,11	0,19	0,25	0,31	0,36	0,41	0,44	0,47
4.000	1,34	2,00	2,72	3,49	4,22	5,05	5,89	6,77	7,30*	7,78*			4.000	0,00	0,04	0,12	0,21	0,28	0,34	0,40	0,45	0,49	0,52
5.000	1,47	2,24	3,06	3,93	4,73	5,61	6,45*						5.000	0,00	0,05	0,15	0,26	0,35	0,43	0,50	0,56	0,62	0,65
6.000	1,51	2,37	3,26	4,17	4,99*								6.000	0,00	0,07	0,18	0,31	0,42	0,51	0,60	0,68	0,74	0,78

* Belt speed is greater than 30 m/s then is necessary to use dynamically balanced pulleys. A reduction in belt life can be expected. Suggested a smaller section.

NARROW WRAPPED V-BELTS DIN



Oleostatic Gold SPZ SECTION

Code	External length LE (mm)	Code	External length LE (mm)	Code	External length LE (mm)	Code	External length LE (mm)	Code	External length LE (mm)	Code	External length LE (mm)	Code	External length LE (mm)
SPZ 487	500	SPZ 812	825	SPZ 1024	1037	SPZ 1250	1263	SPZ 1512	1525	SPZ 1850	1863	SPZ 2262	2275
SPZ 512	525	SPZ 825	838	SPZ 1037	1050	SPZ 1262	1275	SPZ 1520	1533	SPZ 1862	1875	SPZ 2287	2300
SPZ 562	575	SPZ 837	850	SPZ 1047	1060	SPZ 1270	1283	SPZ 1537	1550	SPZ 1887	1900	SPZ 2360	2373
SPZ 587	600	SPZ 850	863	SPZ 1060	1073	SPZ 1287	1300	SPZ 1562	1575	SPZ 1900	1913	SPZ 2410	2423
SPZ 607	620	SPZ 862	875	SPZ 1077	1090	SPZ 1312	1325	SPZ 1587	1600	SPZ 1937	1950	SPZ 2437	2450
SPZ 612	625	SPZ 875	888	SPZ 1087	1100	SPZ 1320	1333	SPZ 1600	1613	SPZ 1962	1975	SPZ 2487	2500
SPZ 630	643	SPZ 887	900	SPZ 1112	1125	SPZ 1337	1350	SPZ 1612	1625	SPZ 1987	2000	SPZ 2500	2513
SPZ 637	650	SPZ 900	913	SPZ 1120	1133	SPZ 1340	1353	SPZ 1637	1650	SPZ 2000	2013	SPZ 2540	2553
SPZ 662	675	SPZ 912	925	SPZ 1137	1150	SPZ 1347	1360	SPZ 1650	1663	SPZ 2019	2032	SPZ 2650	2663
SPZ 670	683	SPZ 922	935	SPZ 1140	1153	SPZ 1362	1375	SPZ 1662	1675	SPZ 2030	2043	SPZ 2690	2703
SPZ 687	700	SPZ 925	938	SPZ 1147	1160	SPZ 1387	1400	SPZ 1687	1700	SPZ 2037	2050	SPZ 2800	2813
SPZ 710	723	SPZ 937	950	SPZ 1150	1163	SPZ 1400	1413	SPZ 1700	1713	SPZ 2062	2075	SPZ 2840	2853
SPZ 722	735	SPZ 950	963	SPZ 1162	1175	SPZ 1412	1425	SPZ 1737	1750	SPZ 2087	2100	SPZ 3000	3013
SPZ 737	750	SPZ 962	975	SPZ 1180	1193	SPZ 1420	1433	SPZ 1750	1763	SPZ 2120	2133	SPZ 3150	3163
SPZ 750	763	SPZ 975	988	SPZ 1187	1200	SPZ 1437	1450	SPZ 1762	1775	SPZ 2137	2150	SPZ 3350	3363
SPZ 762	775	SPZ 987	1000	SPZ 1200	1213	SPZ 1462	1475	SPZ 1787	1800	SPZ 2150	2163	SPZ 3550	3563
SPZ 772	785	SPZ 1000	1013	SPZ 1202	1215	SPZ 1470	1483	SPZ 1800	1813	SPZ 2160	2173		
SPZ 787	800	SPZ 1010	1023	SPZ 1212	1225	SPZ 1487	1500	SPZ 1812	1825	SPZ 2187	2200		
SPZ 800	813	SPZ 1012	1025	SPZ 1237	1250	SPZ 1500	1513	SPZ 1837	1850	SPZ 2240	2253		

TABLE 4 - P_b (kW) referred to Ø (mm)

P_i (kW) referred to i

RPM / Ø	63	71	80	90	100	112	125	140	150	160	170	180	RPM / i	1,00/1,01	1,02/1,05	1,06/1,11	1,12/1,18	1,19/1,26	1,27/1,38	1,39/1,57	1,58/1,94	1,95/3,38	over 3,39
100	0,11	0,14	0,18	0,22	0,27	0,32	0,37	0,43	0,47	0,51	0,56	0,60	100	0,00	0,00	0,00	0,01	0,01	0,01	0,01	0,01	0,02	0,02
200	0,20	0,27	0,34	0,42	0,50	0,60	0,70	0,82	0,90	0,98	1,06	1,13	200	0,00	0,00	0,01	0,01	0,02	0,02	0,03	0,03	0,03	0,03
500	0,43	0,59	0,76	0,96	1,15	1,38	1,62	1,90	2,09	2,27	2,46	2,64	500	0,00	0,01	0,02	0,03	0,05	0,06	0,06	0,07	0,08	0,08
700	0,57	0,78	1,02	1,29	1,55	1,86	2,20	2,58	2,83	3,08	3,34	3,58	700	0,00	0,01	0,03	0,05	0,06	0,08	0,09	0,10	0,11	0,12
900	0,70	0,97	1,27	1,61	1,94	2,33	2,75	3,23	3,55	3,87	4,18	4,49	900	0,00	0,01	0,03	0,06	0,08	0,10	0,12	0,13	0,14	0,15
1.000	0,76	1,06	1,39	1,76	2,13	2,56	3,02	3,55	3,90	4,25	4,59	4,94	1.000	0,00	0,01	0,04	0,07	0,09	0,11	0,13	0,15	0,16	0,17
1.400	0,99	1,40	1,86	2,36	2,85	3,44	4,06	4,78	5,24	5,71	6,16	6,62	1.400	0,00	0,02	0,05	0,09	0,13	0,15	0,18	0,20	0,22	0,23
1.500	1,05	1,48	1,97	2,50	3,02	3,65	4,31	5,07	5,56	6,05	6,54	7,02	1.500	0,00	0,02	0,06	0,10	0,14	0,17	0,19	0,22	0,24	0,25
1.700	1,15	1,64	2,18	2,78	3,36	4,06	4,80	5,64	6,19	6,73	7,26	7,78	1.700	0,00	0,02	0,07	0,11	0,15	0,19	0,22	0,25	0,27	0,29
1.800	1,20	1,72	2,29	2,91	3,53	4,26	5,04	5,92	6,49	7,05	7,61	8,15	1.800	0,00	0,03	0,07	0,12	0,16	0,20	0,23	0,26	0,29	0,30
2.500	1,53	2,22	2,98	3,81	4,62	5,58	6,58	7,70	8,41	9,11	9,79	10,44	2.500	0,00	0,04	0,10	0,17	0,23	0,28	0,32	0,36	0,40	0,42
2.900	1,69	2,47	3,34	4,27	5,18	6,25	7,36	8,58	9,35	10,10	10,81	11,48	2.900	0,00	0,04	0,11	0,19	0,26	0,32	0,37	0,42	0,46	0,49
3.000	1,73	2,53	3,42	4,38	5,32	6,41	7,54	8,78	9,56	10,32	11,03	11,71	3.000	0,00	0,04	0,12	0,20	0,27	0,33	0,39	0,44	0,48	0,50
3.400	1,87	2,76	3,74	4,80	5,82	7,00	8,21	9,52	10,33	11,09	11,81	12,47*	3.400	0,00	0,05	0,13	0,23	0,31	0,37	0,44	0,49	0,54	0,57
3.600	1,94	2,87	3,89	4,99	6,05	7,27	8,51	9,84	10,66	11,42	12,12*	12,75*	3.600	0,00	0,05	0,14	0,24	0,33	0,40	0,46	0,52	0,57	0,60
4.000	2,05	3,07	4,17	5,35	6,48	7,76	9,04	10,38	11,19*	11,91*			4.000	0,00	0,06	0,15	0,27	0,36	0,44	0,52	0,58	0,63	0,67
5.000	2,26	3,45	4,72	6,05	7,29	8,63	9,90*						5.000	0,00	0,07	0,19	0,33	0,45	0,55	0,65	0,73	0,79	0,84
6.000	2,35	3,67	5,05	6,44	7,68*								6.000	0,00	0,08	0,23	0,40	0,55	0,66	0,77	0,87	0,95	1,01

* Belt speed is greater than 30 m/s then is necessary to use dynamically balanced pulleys. A reduction in belt life can be expected. Suggested a smaller section.

NARROW WRAPPED V-BELTS DIN



Extra SPA SECTION

Code	External length LE (mm)	Code	External length LE (mm)	Code	External length LE (mm)	Code	External length LE (mm)	Code	External length LE (mm)	Code	External length LE (mm)	Code	External length LE (mm)
SPA 657	675	SPA 1000	1018	SPA 1332	1350	SPA 1657	1675	SPA 1982	2000	SPA 2500	2518	SPA 3150	3168
SPA 707	725	SPA 1007	1025	SPA 1357	1375	SPA 1682	1700	SPA 2000	2018	SPA 2532	2550	SPA 3182	3200
SPA 732	750	SPA 1032	1050	SPA 1382	1400	SPA 1700	1718	SPA 2032	2050	SPA 2582	2600	SPA 3250	3268
SPA 757	775	SPA 1060	1078	SPA 1400	1418	SPA 1707	1725	SPA 2057	2075	SPA 2607	2625	SPA 3282	3300
SPA 782	800	SPA 1082	1100	SPA 1407	1425	SPA 1732	1750	SPA 2082	2100	SPA 2632	2650	SPA 3350	3368
SPA 800	818	SPA 1107	1125	SPA 1425	1443	SPA 1750	1768	SPA 2120	2138	SPA 2650	2668	SPA 3382	3400
SPA 807	825	SPA 1120	1138	SPA 1432	1450	SPA 1757	1775	SPA 2132	2150	SPA 2682	2700	SPA 3550	3568
SPA 832	850	SPA 1132	1150	SPA 1450	1468	SPA 1782	1800	SPA 2182	2200	SPA 2732	2750	SPA 3650	3668
SPA 850	868	SPA 1150	1168	SPA 1457	1475	SPA 1800	1818	SPA 2207	2225	SPA 2782	2800	SPA 3750	3768
SPA 857	875	SPA 1157	1175	SPA 1482	1500	SPA 1807	1825	SPA 2232	2250	SPA 2800	2818	SPA 4000	4018
SPA 882	900	SPA 1180	1198	SPA 1500	1518	SPA 1832	1850	SPA 2240	2258	SPA 2832	2850	SPA 4250	4268
SPA 900	918	SPA 1207	1225	SPA 1507	1525	SPA 1857	1875	SPA 2282	2300	SPA 2847	2865	SPA 4500	4518
SPA 907	925	SPA 1232	1250	SPA 1532	1550	SPA 1882	1900	SPA 2300	2318	SPA 2882	2900	SPA 4750	4768
SPA 925	943	SPA 1250	1268	SPA 1550	1568	SPA 1900	1918	SPA 2307	2325	SPA 2900	2918		
SPA 932	950	SPA 1257	1275	SPA 1557	1575	SPA 1907	1925	SPA 2332	2350	SPA 2932	2950		
SPA 950	968	SPA 1272	1290	SPA 1582	1600	SPA 1925	1943	SPA 2360	2378	SPA 2982	3000		
SPA 957	975	SPA 1282	1300	SPA 1600	1618	SPA 1932	1950	SPA 2382	2400	SPA 3000	3018		
SPA 967	985	SPA 1307	1325	SPA 1607	1625	SPA 1950	1968	SPA 2432	2450	SPA 3032	3050		
SPA 982	1000	SPA 1320	1338	SPA 1632	1650	SPA 1957	1975	SPA 2482	2500	SPA 3082	3100		

TABLE 4 - P_b (kW) referred to Ø (mm)

P_d (kW) referred to i

RPM / Ø	90	100	106	112	118	132	150	170	190	212	236	250	RPM / i	1,00/1,01	1,02/1,05	1,06/1,11	1,12/1,18	1,19/1,26	1,27/1,38	1,39/1,57	1,58/1,94	1,95/3,38	over 3,38
100	0,18	0,23	0,26	0,29	0,31	0,38	0,46	0,55	0,64	0,74	0,85	0,91	100	0,00	0,00	0,01	0,01	0,02	0,02	0,02	0,03	0,03	0,03
200	0,33	0,42	0,47	0,53	0,58	0,70	0,86	1,04	1,21	1,40	1,61	1,72	200	0,00	0,01	0,01	0,02	0,03	0,04	0,05	0,05	0,06	0,06
500	0,70	0,91	1,04	1,17	1,29	1,58	1,95	2,36	2,77	3,21	3,68	3,96	500	0,00	0,01	0,04	0,06	0,08	0,10	0,12	0,13	0,15	0,15
700	0,92	1,21	1,38	1,55	1,72	2,12	2,63	3,18	3,73	4,32	4,97	5,34	700	0,00	0,02	0,05	0,09	0,12	0,14	0,17	0,19	0,20	0,22
900	1,12	1,48	1,70	1,92	2,13	2,63	3,27	3,96	4,64	5,38	6,18	6,64	900	0,00	0,02	0,06	0,11	0,15	0,18	0,21	0,24	0,26	0,28
1.000	1,21	1,62	1,85	2,09	2,33	2,88	3,57	4,34	5,08	5,89	6,76	7,26	1.000	0,00	0,03	0,07	0,12	0,17	0,20	0,24	0,27	0,29	0,31
1.400	1,56	2,11	2,43	2,75	3,07	3,81	4,74	5,75	6,74	7,79	8,91	9,54	1.400	0,00	0,04	0,10	0,17	0,23	0,28	0,33	0,37	0,41	0,43
1.500	1,64	2,22	2,57	2,91	3,25	4,03	5,01	6,08	7,12	8,23	9,40	10,05	1.500	0,00	0,04	0,11	0,18	0,25	0,30	0,36	0,40	0,44	0,46
1.700	1,80	2,44	2,82	3,21	3,58	4,45	5,54	6,72	7,85	9,06	10,31	11,01	1.700	0,00	0,04	0,12	0,21	0,28	0,34	0,40	0,45	0,49	0,52
1.800	1,87	2,55	2,95	3,35	3,74	4,65	5,79	7,02	8,20	9,45	10,74	11,46	1.800	0,00	0,05	0,13	0,22	0,30	0,36	0,43	0,48	0,52	0,55
2.500	2,31	3,20	3,72	4,24	4,75	5,92	7,35	8,85	10,25	11,66	13,03*	13,74*	2.500	0,00	0,06	0,18	0,31	0,42	0,51	0,59	0,67	0,73	0,77
2.900	2,50	3,50	4,09	4,66	5,23	6,51	8,05	9,64	11,08	12,46*			2.900	0,00	0,08	0,20	0,36	0,48	0,59	0,69	0,77	0,84	0,89
3.000	2,55	3,57	4,17	4,76	5,34	6,64	8,21	9,81	11,24	12,60*			3.000	0,00	0,08	0,21	0,37	0,50	0,61	0,71	0,80	0,87	0,92
3.500	2,72	3,86	4,52	5,16	5,79	7,19	8,83	10,43*	11,77*				3.500	0,00	0,09	0,25	0,43	0,59	0,71	0,83	0,93	1,02	1,08
3.600	2,74	3,90	4,58	5,23	5,87	7,28	8,92	10,51*					3.600	0,00	0,09	0,25	0,44	0,60	0,73	0,85	0,96	1,05	1,11
4.000	2,82	4,05	4,76	5,45	6,11	7,55	9,18*						4.000	0,00	0,10	0,28	0,49	0,67	0,81	0,95	1,07	1,16	1,23
4.600	2,85	4,16	4,90	5,61	6,28	7,71*							4.600	0,00	0,12	0,32	0,57	0,77	0,93	1,09	1,23	1,34	1,42
5.000	2,80	4,14	4,89	5,60	6,27*	7,63*							5.000	0,00	0,13	0,35	0,61	0,84	1,01	1,19	1,34	1,45	1,54

* Belt speed is greater than 30 m/s then is necessary to use dynamically balanced pulleys. A reduction in belt life can be expected. Suggested a smaller section.

NARROW WRAPPED V-BELTS DIN



Oleostatic Gold SPA SECTION

Code	External length LE (mm)	Code	External length LE (mm)	Code	External length LE (mm)	Code	External length LE (mm)	Code	External length LE (mm)	Code	External length LE (mm)	Code	External length LE (mm)
SPA 657	675	SPA 982	1000	SPA 1307	1325	SPA 1600	1618	SPA 1925	1943	SPA 2332	2350	SPA 2900	2918
SPA 707	725	SPA 1000	1018	SPA 1320	1338	SPA 1607	1625	SPA 1932	1950	SPA 2360	2378	SPA 2932	2950
SPA 732	750	SPA 1007	1025	SPA 1332	1350	SPA 1632	1650	SPA 1950	1968	SPA 2382	2400	SPA 2982	3000
SPA 757	775	SPA 1032	1050	SPA 1357	1375	SPA 1657	1675	SPA 1957	1975	SPA 2432	2450	SPA 3000	3018
SPA 782	800	SPA 1060	1078	SPA 1382	1400	SPA 1682	1700	SPA 1982	2000	SPA 2482	2500	SPA 3032	3050
SPA 800	818	SPA 1082	1100	SPA 1400	1418	SPA 1700	1718	SPA 2000	2018	SPA 2500	2518	SPA 3082	3100
SPA 807	825	SPA 1107	1125	SPA 1407	1425	SPA 1707	1725	SPA 2032	2050	SPA 2532	2550	SPA 3150	3168
SPA 832	850	SPA 1120	1138	SPA 1425	1443	SPA 1732	1750	SPA 2057	2075	SPA 2582	2600	SPA 3182	3200
SPA 850	868	SPA 1132	1150	SPA 1432	1450	SPA 1750	1768	SPA 2082	2100	SPA 2607	2625	SPA 3250	3268
SPA 857	875	SPA 1150	1168	SPA 1450	1468	SPA 1757	1775	SPA 2120	2138	SPA 2632	2650	SPA 3282	3300
SPA 882	900	SPA 1157	1175	SPA 1457	1475	SPA 1782	1800	SPA 2132	2150	SPA 2650	2668	SPA 3350	3368
SPA 900	918	SPA 1180	1198	SPA 1482	1500	SPA 1800	1818	SPA 2182	2200	SPA 2682	2700	SPA 3382	3400
SPA 907	925	SPA 1207	1225	SPA 1500	1518	SPA 1807	1825	SPA 2207	2225	SPA 2732	2750	SPA 3550	3568
SPA 925	943	SPA 1232	1250	SPA 1507	1525	SPA 1832	1850	SPA 2232	2250	SPA 2782	2800	SPA 3650	3668
SPA 932	950	SPA 1250	1268	SPA 1532	1550	SPA 1857	1875	SPA 2240	2258	SPA 2800	2818	SPA 3750	3768
SPA 950	968	SPA 1257	1275	SPA 1550	1568	SPA 1882	1900	SPA 2282	2300	SPA 2832	2850	SPA 4000	4018
SPA 957	975	SPA 1272	1290	SPA 1557	1575	SPA 1900	1918	SPA 2300	2318	SPA 2847	2865	SPA 4250	4268
SPA 967	985	SPA 1282	1300	SPA 1582	1600	SPA 1907	1925	SPA 2307	2325	SPA 2882	2900	SPA 4500	4518
												SPA 4750	4768

TABLE 4 - P_b (kW) referred to Ø (mm)

P_d (kW) referred to i

RPM / Ø	90	100	106	112	118	132	150	170	190	212	236	250	RPM / i	1,00/1,01	1,02/1,05	1,06/1,11	1,12/1,18	1,19/1,26	1,27/1,38	1,39/1,57	1,58/1,94	1,95/3,38	over 3,39
100	0,26	0,33	0,37	0,41	0,46	0,55	0,68	0,82	0,95	1,10	1,27	1,36	100	0,00	0,00	0,01	0,02	0,02	0,03	0,03	0,03	0,04	0,04
200	0,47	0,61	0,69	0,77	0,85	1,04	1,28	1,55	1,81	2,10	2,41	2,59	200	0,00	0,01	0,02	0,03	0,04	0,05	0,06	0,07	0,07	0,08
500	1,02	1,34	1,54	1,73	1,92	2,37	2,94	3,56	4,18	4,86	5,59	6,02	500	0,00	0,02	0,05	0,08	0,11	0,13	0,15	0,17	0,19	0,20
700	1,34	1,79	2,05	2,32	2,58	3,19	3,97	4,82	5,66	6,58	7,57	8,14	700	0,00	0,02	0,06	0,11	0,15	0,18	0,21	0,24	0,26	0,28
900	1,65	2,21	2,54	2,88	3,21	3,98	4,95	6,02	7,08	8,22	9,45	10,16	900	0,00	0,03	0,08	0,14	0,19	0,23	0,27	0,31	0,34	0,35
1.000	1,79	2,41	2,78	3,15	3,51	4,36	5,43	6,60	7,76	9,01	10,36	11,13	1.000	0,00	0,03	0,09	0,16	0,21	0,26	0,30	0,34	0,37	0,39
1.400	2,33	3,17	3,67	4,17	4,66	5,80	7,24	8,80	10,33	11,96	13,69	14,67	1.400	0,00	0,05	0,13	0,22	0,30	0,36	0,43	0,48	0,52	0,55
1.500	2,45	3,35	3,88	4,41	4,93	6,14	7,66	9,32	10,93	12,65	14,45	15,47	1.500	0,00	0,05	0,14	0,24	0,32	0,39	0,46	0,51	0,56	0,59
1.700	2,69	3,69	4,28	4,87	5,45	6,80	8,48	10,31	12,07	13,93	15,87	16,96	1.700	0,00	0,06	0,15	0,27	0,36	0,44	0,52	0,58	0,63	0,67
1.800	2,81	3,86	4,48	5,10	5,71	7,11	8,88	10,78	12,61	14,54	16,53	17,64	1.800	0,00	0,06	0,16	0,28	0,39	0,47	0,55	0,62	0,67	0,71
2.500	3,50	4,88	5,70	6,50	7,29	9,09	11,31	13,63	15,78	17,95	20,04*	21,12*	2.500	0,00	0,08	0,23	0,39	0,53	0,65	0,76	0,85	0,93	0,99
2.900	3,82	5,36	6,27	7,16	8,04	10,02	12,41	14,85	17,05	19,15*			2.900	0,00	0,10	0,26	0,46	0,62	0,75	0,88	0,99	1,08	1,14
3.000	3,88	5,47	6,40	7,31	8,21	10,22	12,65	15,11	17,30	19,36*			3.000	0,00	0,10	0,27	0,47	0,64	0,78	0,91	1,03	1,12	1,18
3.500	4,17	5,93	6,95	7,95	8,92	11,08	13,60	16,04*	18,06*				3.500	0,00	0,12	0,32	0,55	0,75	0,91	1,06	1,20	1,30	1,38
3.600	4,21	6,00	7,05	8,06	9,04	11,21	13,74	16,15*					3.600	0,00	0,12	0,32	0,57	0,77	0,93	1,09	1,23	1,34	1,42
4.000	4,34	6,24	7,34	8,40	9,42	11,63	14,12*						4.000	0,00	0,13	0,36	0,63	0,86	1,04	1,21	1,37	1,49	1,58
4.600	4,39	6,41	7,56	8,65	9,68	11,84*							4.600	0,00	0,15	0,41	0,72	0,98	1,19	1,40	1,57	1,71	1,81
5.000	4,32	6,39	7,54	8,62	9,63*	11,69*							5.000	0,00	0,17	0,45	0,79	1,07	1,30	1,52	1,71	1,86	1,97

* Belt speed is greater than 30 m/s then is necessary to use dynamically balanced pulleys. A reduction in belt life can be expected. Suggested a smaller section.

NARROW WRAPPED V-BELTS DIN



Extra SPB SECTION

Code	External length LE (mm)	Code	External length LE (mm)	Code	External length LE (mm)	Code	External length LE (mm)	Code	External length LE (mm)	Code	External length LE (mm)	Code	External length LE (mm)
SPB 1250	1272	SPB 1860	1882	SPB 2280	2302	SPB 2650	2672	SPB 3250	3272	SPB 4500	4522	SPB 7500	7522
SPB 1320	1342	SPB 1900	1922	SPB 2300	2322	SPB 2680	2702	SPB 3320	3342	SPB 4560	4582	SPB 8000	8022
SPB 1400	1422	SPB 1950	1972	SPB 2360	2382	SPB 2720	2742	SPB 3350	3372	SPB 4750	4772		
SPB 1410	1432	SPB 2000	2022	SPB 2391	2413	SPB 2800	2822	SPB 3450	3472	SPB 4820	4842		
SPB 1450	1472	SPB 2020	2042	SPB 2400	2422	SPB 2840	2862	SPB 3550	3572	SPB 5000	5022		
SPB 1500	1522	SPB 2060	2082	SPB 2410	2432	SPB 2850	2872	SPB 3650	3672	SPB 5070	5092		
SPB 1600	1622	SPB 2098	2120	SPB 2430	2452	SPB 2900	2922	SPB 3750	3772	SPB 5300	5322		
SPB 1650	1672	SPB 2120	2142	SPB 2450	2472	SPB 2950	2972	SPB 3800	3822	SPB 5600	5622		
SPB 1700	1722	SPB 2150	2172	SPB 2500	2522	SPB 3000	3022	SPB 4000	4022	SPB 6000	6022		
SPB 1750	1772	SPB 2180	2202	SPB 2530	2552	SPB 3070	3092	SPB 4050	4072	SPB 6300	6322		
SPB 1800	1822	SPB 2240	2262	SPB 2580	2602	SPB 3150	3172	SPB 4250	4272	SPB 6700	6722		
SPB 1850	1872	SPB 2264	2286	SPB 2600	2622	SPB 3170	3192	SPB 4300	4322	SPB 7100	7122		

TABLE 4 - P_b (kW) referred to \emptyset (mm)

P_a (kW) referred to i

RPM / \emptyset	140	150	160	170	180	200	225	250	280	315	355	400	RPM / i	1,00/1,01	1,02/1,05	1,06/1,11	1,12/1,18	1,19/1,26	1,27/1,38	1,39/1,57	1,58/1,94	1,95/3,38	over 3,38
100	0,51	0,59	0,66	0,73	0,81	0,95	1,13	1,31	1,53	1,78	2,06	2,37	100	0,00	0,01	0,02	0,03	0,04	0,04	0,05	0,06	0,06	0,07
200	0,93	1,07	1,22	1,36	1,50	1,78	2,12	2,46	2,87	3,34	3,88	4,47	200	0,00	0,01	0,03	0,05	0,07	0,09	0,10	0,12	0,13	0,14
500	2,02	2,36	2,69	3,02	3,34	3,99	4,79	5,59	6,53	7,61	8,83	10,18	500	0,00	0,03	0,08	0,13	0,18	0,22	0,26	0,29	0,32	0,34
700	2,67	3,12	3,57	4,02	4,46	5,34	6,42	7,49	8,75	10,20	11,82	13,59	700	0,00	0,04	0,11	0,19	0,26	0,31	0,36	0,41	0,45	0,47
900	3,27	3,83	4,40	4,95	5,51	6,60	7,95	9,27	10,83	12,59	14,55	16,67	900	0,00	0,05	0,14	0,24	0,33	0,40	0,47	0,53	0,57	0,61
1.000	3,55	4,17	4,79	5,40	6,01	7,21	8,68	10,12	11,80	13,71	15,82	18,07	1.000	0,00	0,06	0,15	0,27	0,37	0,44	0,52	0,59	0,64	0,68
1.400	4,59	5,42	6,24	7,05	7,85	9,42	11,33	13,18	15,30	17,64	20,12	22,64	1.400	0,00	0,08	0,22	0,38	0,51	0,62	0,73	0,82	0,89	0,95
1.500	4,82	5,70	6,57	7,42	8,27	9,93	11,93	13,86	16,06	18,46	20,98	23,49*	1.500	0,00	0,09	0,23	0,40	0,55	0,67	0,78	0,88	0,96	1,01
1.700	5,26	6,23	7,19	8,13	9,06	10,87	13,04	15,10	17,43	19,91	22,42*		1.700	0,00	0,10	0,26	0,46	0,62	0,75	0,88	1,00	1,08	1,15
1.800	5,47	6,48	7,48	8,47	9,43	11,31	13,55	15,67	18,03	20,53	22,99*		1.800	0,00	0,10	0,28	0,48	0,66	0,80	0,94	1,05	1,15	1,22
2.000	5,85	6,95	8,03	9,09	10,12	12,12	14,48	16,67	19,07	21,52*			2.000	0,00	0,11	0,31	0,54	0,73	0,89	1,04	1,17	1,28	1,35
2.500	6,63	7,90	9,14	10,34	11,50	13,70	16,19	18,38*					2.500	0,00	0,14	0,39	0,67	0,92	1,11	1,30	1,46	1,59	1,69
2.900	7,05	8,43	9,75	11,02	12,23	14,46*	16,86*						2.900	0,00	0,16	0,45	0,78	1,06	1,29	1,51	1,70	1,85	1,96
3.000	7,13	8,53	9,87	11,14	12,35	14,57*							3.000	0,00	0,17	0,46	0,81	1,10	1,33	1,56	1,76	1,91	2,03
3.500	7,32	8,78	10,15	11,42*	12,59*								3.500	0,00	0,20	0,54	0,94	1,28	1,55	1,82	2,05	2,23	2,36
3.600	7,32	8,78	10,14	11,40*	12,56*								3.600	0,00	0,20	0,56	0,97	1,32	1,60	1,87	2,11	2,30	2,43
4.000	7,17	8,61*	9,93*										4.000	0,00	0,23	0,62	1,08	1,47	1,78	2,08	2,34	2,55	2,70
4.600	6,48*												4.600	0,00	0,26	0,71	1,24	1,69	2,04	2,39	2,69	2,93	3,11

* Belt speed is greater than 30 m/s then is necessary to use dynamically balanced pulleys. A reduction in belt life can be expected. Suggested a smaller section.

NARROW WRAPPED V-BELTS DIN



Oleostatic Gold SPB SECTION

Code	External length LE (mm)	Code	External length LE (mm)	Code	External length LE (mm)	Code	External length LE (mm)	Code	External length LE (mm)	Code	External length LE (mm)	Code	External length LE (mm)
SPB 1250	1272	SPB 1850	1872	SPB 2240	2262	SPB 2530	2552	SPB 3000	3022	SPB 3800	3822	SPB 5300	5322
SPB 1320	1342	SPB 1860	1882	SPB 2264	2286	SPB 2580	2602	SPB 3070	3092	SPB 4000	4022	SPB 5600	5622
SPB 1400	1422	SPB 1900	1922	SPB 2280	2302	SPB 2600	2622	SPB 3150	3172	SPB 4050	4072	SPB 6000	6022
SPB 1410	1432	SPB 1950	1972	SPB 2300	2322	SPB 2650	2672	SPB 3170	3192	SPB 4250	4272	SPB 6300	6322
SPB 1450	1472	SPB 2000	2022	SPB 2360	2382	SPB 2680	2702	SPB 3250	3272	SPB 4300	4322	SPB 6700	6722
SPB 1500	1522	SPB 2020	2042	SPB 2391	2413	SPB 2720	2742	SPB 3320	3342	SPB 4500	4522	SPB 7100	7122
SPB 1600	1622	SPB 2060	2082	SPB 2400	2422	SPB 2800	2822	SPB 3350	3372	SPB 4560	4582	SPB 7500	7522
SPB 1650	1672	SPB 2098	2120	SPB 2410	2432	SPB 2840	2862	SPB 3450	3472	SPB 4750	4772	SPB 8000	8022
SPB 1700	1722	SPB 2120	2142	SPB 2430	2452	SPB 2850	2872	SPB 3550	3572	SPB 4820	4842		
SPB 1750	1772	SPB 2150	2172	SPB 2450	2472	SPB 2900	2922	SPB 3650	3672	SPB 5000	5022		
SPB 1800	1822	SPB 2180	2202	SPB 2500	2522	SPB 2950	2972	SPB 3750	3772	SPB 5070	5092		

TABLE 4 - P_b (kW) referred to Ø (mm)

P_a (kW) referred to i

RPM / Ø	140	150	160	170	180	200	225	250	280	315	355	400	RPM / i	1,00/1,01	1,02/1,05	1,06/1,11	1,12/1,18	1,19/1,26	1,27/1,38	1,39/1,57	1,58/1,94	1,95/3,38	over 3,39
100	0,73	0,84	0,95	1,06	1,17	1,38	1,65	1,92	2,24	2,61	3,03	3,50	100	0,00	0,01	0,02	0,03	0,05	0,06	0,07	0,08	0,08	0,09
200	1,34	1,55	1,76	1,97	2,18	2,60	3,12	3,63	4,25	4,96	5,76	6,66	200	0,00	0,01	0,04	0,07	0,09	0,11	0,13	0,15	0,16	0,17
500	2,96	3,46	3,96	4,45	4,95	5,93	7,15	8,35	9,78	11,43	13,29	15,35	500	0,00	0,04	0,10	0,17	0,24	0,28	0,33	0,38	0,41	0,43
700	3,93	4,61	5,29	5,97	6,64	7,98	9,63	11,25	13,18	15,38	17,85	20,56	700	0,00	0,05	0,14	0,24	0,33	0,40	0,47	0,53	0,57	0,61
900	4,84	5,70	6,55	7,40	8,24	9,91	11,96	13,98	16,35	19,05	22,04	25,28	900	0,00	0,07	0,18	0,31	0,42	0,51	0,60	0,68	0,74	0,78
1.000	5,27	6,22	7,15	8,08	9,01	10,84	13,08	15,28	17,85	20,77	23,98	27,42	1.000	0,00	0,07	0,20	0,35	0,47	0,57	0,67	0,75	0,82	0,87
1.400	6,86	8,13	9,38	10,62	11,84	14,25	17,16	19,98	23,22	26,78	30,55	34,37	1.400	0,00	0,10	0,28	0,48	0,66	0,80	0,93	1,05	1,15	1,21
1.500	7,23	8,57	9,89	11,20	12,49	15,02	18,08	21,02	24,38	28,04	31,86	35,64*	1.500	0,00	0,11	0,30	0,52	0,71	0,85	1,00	1,13	1,23	1,30
1.700	7,91	9,40	10,86	12,30	13,72	16,48	19,79	22,94	26,47	30,23	34,01*		1.700	0,00	0,12	0,34	0,59	0,80	0,97	1,13	1,28	1,39	1,47
1.800	8,24	9,79	11,31	12,82	14,29	17,16	20,58	23,80	27,39	31,16	34,85*		1.800	0,00	0,13	0,36	0,62	0,85	1,03	1,20	1,35	1,47	1,56
2.000	8,83	10,51	12,16	13,77	15,35	18,40	22,00	25,33	28,96	32,62*			2.000	0,00	0,15	0,40	0,69	0,94	1,14	1,34	1,50	1,64	1,73
2.500	10,06	12,00	13,89	15,72	17,49	20,82	24,59	27,87*					2.500	0,00	0,18	0,50	0,86	1,18	1,42	1,67	1,88	2,05	2,17
2.900	10,73	12,83	14,84	16,76	18,59	21,95*	25,54*						2.900	0,00	0,21	0,57	1,00	1,36	1,65	1,94	2,18	2,37	2,51
3.000	10,85	12,98	15,01	16,95	18,78	22,11*							3.000	0,00	0,22	0,59	1,04	1,41	1,71	2,00	2,25	2,46	2,60
3.500	11,16	13,36	15,43	17,34*	19,09*								3.500	0,00	0,25	0,69	1,21	1,65	1,99	2,34	2,63	2,86	3,03
3.600	11,16	13,36	15,42	17,31*	19,02*								3.600	0,00	0,26	0,71	1,24	1,69	2,05	2,40	2,70	2,95	3,12
4.000	10,92	13,09*	15,05*										4.000	0,00	0,29	0,79	1,38	1,88	2,28	2,67	3,01	3,27	3,47
4.600	9,82*												4.600	0,00	0,33	0,91	1,59	2,16	2,62	3,07	3,46	3,76	3,99

* Belt speed is greater than 30 m/s then is necessary to use dynamically balanced pulleys. A reduction in belt life can be expected. Suggested a smaller section.

NARROW WRAPPED V-BELTS DIN

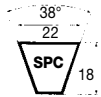

Extra SPC SECTION

Code	External length LE (mm)	Code	External length LE (mm)	Code	External length LE (mm)	Code	External length LE (mm)	Code	External length LE (mm)	Code	External length LE (mm)	Code	External length LE (mm)
SPC 2000	2030	SPC 2650	2680	SPC 3550	3580	SPC 4500	4530	SPC 6000	6030	SPC 8000	8030	SPC 10600	10630
SPC 2120	2150	SPC 2800	2830	SPC 3750	3780	SPC 4750	4780	SPC 6300	6330	SPC 8500	8530	SPC 11200	11230
SPC 2240	2270	SPC 3000	3030	SPC 4000	4030	SPC 5000	5030	SPC 6700	6730	SPC 9000	9030	SPC 11800	11830
SPC 2360	2390	SPC 3150	3180	SPC 4250	4280	SPC 5300	5330	SPC 7100	7130	SPC 9500	9530	SPC 12000	12030
SPC 2500	2530	SPC 3350	3380	SPC 4400	4430	SPC 5600	5630	SPC 7500	7530	SPC 10000	10030	SPC 12500	12530

TABLE 4 - P_b (kW) referred to \emptyset (mm)

P_d (kW) referred to i

RPM / \emptyset	224	236	250	280	315	355	400	450	500	560	600	630	RPM / i	1,00/1,01	1,02/1,05	1,06/1,11	1,12/1,18	1,19/1,26	1,27/1,38	1,39/1,57	1,58/1,94	1,95/3,38	over 3,38
50	0,84	0,92	1,02	1,23	1,46	1,73	2,04	2,37	2,70	3,09	3,35	3,55	50	0,00	0,01	0,02	0,04	0,05	0,06	0,07	0,08	0,09	0,09
100	1,55	1,71	1,89	2,29	2,74	3,26	3,83	4,47	5,10	5,85	6,34	6,71	100	0,00	0,02	0,04	0,07	0,10	0,12	0,14	0,16	0,18	0,19
150	2,21	2,44	2,71	3,28	3,94	4,70	5,54	6,46	7,38	8,47	9,19	9,72	150	0,00	0,02	0,06	0,11	0,15	0,18	0,22	0,24	0,27	0,28
200	2,83	3,13	3,48	4,23	5,10	6,08	7,18	8,38	9,57	10,99	11,93	12,62	200	0,00	0,03	0,09	0,15	0,20	0,25	0,29	0,33	0,35	0,38
300	4,01	4,45	4,96	6,05	7,31	8,73	10,31	12,05	13,77	15,80	17,14	18,14	300	0,00	0,05	0,13	0,22	0,31	0,37	0,43	0,49	0,53	0,56
400	5,11	5,68	6,35	7,77	9,40	11,25	13,29	15,53	17,74	20,34	22,04	23,31	400	0,00	0,06	0,17	0,30	0,41	0,49	0,58	0,65	0,71	0,75
600	7,15	7,98	8,94	10,97	13,31	15,93	18,82	21,95	25,01	28,55	30,84	32,52	600	0,00	0,09	0,26	0,45	0,61	0,74	0,87	0,98	1,06	1,13
700	8,10	9,04	10,14	12,47	15,13	18,10	21,37	24,89	28,28	32,19	34,69	36,51	700	0,00	0,11	0,30	0,52	0,71	0,86	1,01	1,14	1,24	1,31
750	8,55	9,56	10,72	13,19	16,01	19,15	22,59	26,28	29,83	33,89	36,46	38,32	750	0,00	0,12	0,32	0,56	0,76	0,92	1,08	1,22	1,33	1,41
900	9,86	11,03	12,39	15,25	18,50	22,11	26,01	30,14	34,05	38,41	41,10	43,01	900	0,00	0,14	0,39	0,67	0,92	1,11	1,30	1,46	1,59	1,69
1.000	10,67	11,95	13,43	16,53	20,05	23,92	28,08	32,43	36,48	40,91	43,59*	45,43*	1.000	0,00	0,16	0,43	0,75	1,02	1,23	1,44	1,63	1,77	1,88
1.400	13,47	15,12	17,00	20,91	25,23	29,80	34,47		42,74*				1.400	0,00	0,22	0,60	1,05	1,42	1,73	2,02	2,28	2,48	2,63
1.500	14,05	15,77	17,74	21,80	26,24	30,89	35,53*						1.500	0,00	0,24	0,64	1,12	1,53	1,85	2,17	2,44	2,66	2,81
1.700	15,05	16,91	19,01	23,30	27,88	32,53*							1.700	0,00	0,27	0,73	1,27	1,73	2,10	2,46	2,76	3,01	3,19
1.800	15,48	17,38	19,54	23,90	28,51								1.800	0,00	0,28	0,77	1,35	1,83	2,22	2,60	2,93	3,19	3,38
2.000	16,15	18,14	20,37	24,80									2.000	0,00	0,31	0,86	1,49	2,03	2,47	2,89	3,25	3,54	3,75
2.500	16,74	18,77*	20,96*										2.500	0,00	0,39	1,07	1,87	2,54	3,08	3,61	4,06	4,43	4,69



* Belt speed is greater than 30 m/s then is necessary to use dynamically balanced pulleys. A reduction in belt life can be expected. Suggested a smaller section.

NARROW WRAPPED V-BELTS DIN



Oleostatic Gold SPC SECTION

Code	External length LE (mm)	Code	External length LE (mm)	Code	External length LE (mm)	Code	External length LE (mm)	Code	External length LE (mm)	Code	External length LE (mm)
SPC 2000	2030	SPC 2800	2830	SPC 4000	4030	SPC 5300	5330	SPC 7500	7530	SPC 10600	10630
SPC 2120	2150	SPC 3000	3030	SPC 4250	4280	SPC 5600	5630	SPC 8000	8030	SPC 11200	11230
SPC 2240	2270	SPC 3150	3180	SPC 4400	4430	SPC 6000	6030	SPC 8500	8530	SPC 11800	11830
SPC 2360	2390	SPC 3350	3380	SPC 4500	4530	SPC 6300	6330	SPC 9000	9030	SPC 12000	12030
SPC 2500	2530	SPC 3550	3580	SPC 4750	4780	SPC 6700	6730	SPC 9500	9530	SPC 12500	12530
SPC 2650	2680	SPC 3750	3780	SPC 5000	5030	SPC 7100	7130	SPC 10000	10030		

TABLE 4 - P_b (kW) referred to Ø (mm)

P_d (kW) referred to i

RPM / Ø	224	236	250	280	315	355	400	450	500	560	600	630	RPM / i	1,00/1,01	1,02/1,05	1,06/1,11	1,12/1,18	1,19/1,26	1,27/1,38	1,39/1,57	1,58/1,94	1,95/3,38	over 3,39
50	1,21	1,34	1,48	1,79	2,15	2,56	3,01	3,52	4,01	4,61	5,01	5,30	50	0,00	0,01	0,03	0,05	0,06	0,08	0,09	0,10	0,11	0,12
100	2,26	2,50	2,77	3,37	4,06	4,84	5,72	6,69	7,64	8,79	9,55	10,11	100	0,00	0,02	0,05	0,09	0,13	0,15	0,18	0,20	0,22	0,23
150	3,23	3,59	3,99	4,87	5,88	7,02	8,31	9,72	11,12	12,79	13,89	14,72	150	0,00	0,03	0,08	0,14	0,19	0,23	0,27	0,30	0,33	0,35
200	4,17	4,63	5,17	6,31	7,63	9,13	10,81	12,65	14,48	16,66	18,10	19,17	200	0,00	0,04	0,11	0,19	0,25	0,31	0,36	0,41	0,44	0,47
300	5,94	6,62	7,40	9,07	11,00	13,19	15,62	18,30	20,94	24,08	26,15	27,69	300	0,00	0,06	0,16	0,28	0,38	0,46	0,54	0,61	0,66	0,70
400	7,62	8,50	9,53	11,70	14,22	17,06	20,21	23,67	27,08	31,09	33,73	35,69	400	0,00	0,08	0,21	0,37	0,51	0,62	0,72	0,81	0,88	0,94
600	10,75	12,03	13,51	16,64	20,25	24,30	28,77	33,62	38,34	43,83	47,37	49,97	600	0,00	0,12	0,32	0,56	0,76	0,92	1,08	1,22	1,33	1,40
700	12,22	13,68	15,37	18,96	23,08	27,68	32,73	38,17	43,43	49,47	53,33	56,13	700	0,00	0,14	0,37	0,65	0,89	1,08	1,26	1,42	1,55	1,64
750	12,92	14,48	16,28	20,08	24,44	29,30	34,62	40,33	45,82	52,09	56,06	58,92	750	0,00	0,15	0,40	0,70	0,95	1,15	1,35	1,52	1,66	1,76
900	14,95	16,77	18,86	23,29	28,32	33,90	39,94	46,32	52,34	59,04	63,17	66,08	900	0,00	0,18	0,48	0,84	1,14	1,39	1,62	1,83	1,99	2,11
1.000	16,22	18,20	20,49	25,29	30,74	36,73	43,15	49,86	56,09	62,87	66,93*	69,72*	1.000	0,00	0,20	0,54	0,93	1,27	1,54	1,80	2,03	2,21	2,34
1.400	20,60	23,16	26,07	32,12	38,77	45,81	52,95	60,40*					1.400	0,00	0,28	0,75	1,31	1,78	2,15	2,52	2,84	3,09	3,28
1.500	21,52	24,18	27,23	33,49	40,33	47,46	54,53*						1.500	0,00	0,29	0,80	1,40	1,91	2,31	2,70	3,04	3,32	3,51
1.700	23,10	25,96	29,21	35,81	42,84	49,91*							1.700	0,00	0,33	0,91	1,59	2,16	2,62	3,06	3,45	3,76	3,98
1.800	23,76	26,70	30,03	36,73	43,77								1.800	0,00	0,35	0,96	1,68	2,29	2,77	3,24	3,65	3,98	4,21
2.000	24,81	27,87	31,30	38,07									2.000	0,00	0,39	1,07	1,87	2,54	3,08	3,61	4,06	4,42	4,68
2.500	25,68	28,76*	32,08*										2.500	0,00	0,49	1,34	2,33	3,18	3,85	4,51	5,07	5,53	5,85



* Belt speed is greater than 30 m/s then is necessary to use dynamically balanced pulleys. A reduction in belt life can be expected. Suggested a smaller section.

NARROW WRAPPED V-BELTS RMA



BELT CHARACTERISTICS

section	3V	5V	8V
a (mm)	9	15	25
s (mm)	8	13	23
pitch length - internal length = Δi (mm)	31	54	103
external length - pitch length = Δe (mm)	20	27	41
weight (gr/m)	90	210	620
min. pulley diam. (mm)	50	170	315
working temperature	-30°C / +80°C		
relevant standards	RMA/MTPA IP22 - ASAE S 211-4		
relevant antistatic standard	ISO 1813		
materials	CR blend - polyester cord - cotton/polyester fabric		

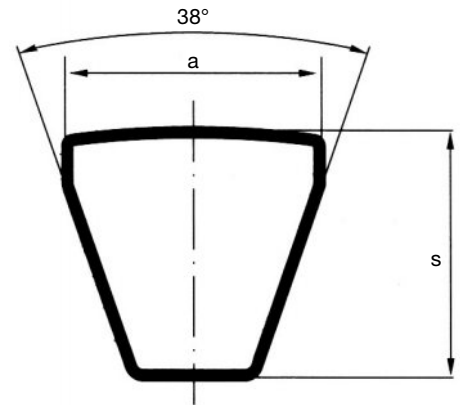

TABLE 3 - CORRECTION FACTOR C_L according to type and length of the belt

	635	850	1080	1205	1270	1700	2030	2415	2690	3175	3555	3810	4570	5690	8000	8500	9000	10800	12060	12700	
3V	0,83	0,88	0,93	0,95	0,96	1,01	1,04	1,08	1,10	1,13	1,15										
5V					0,85	0,90	0,93	0,96	0,97	1,00	1,02	1,03	1,06	1,09	1,15	1,16	1,17				
8V									0,88	0,90	0,92	0,93	0,95	0,98	1,03	1,04	1,05	1,08	1,09	1,10	

TABLE 5 - INSTALLATION AND TAKE UP ALLOWANCE

L (mm)	Y (mm)			X (mm)
	3V	5V	8V	
635 / 1145	15			25
1205 / 3555	20	25	40	55
3810 / 5080		25	45	65
5385 / 6350		35	45	105
6730 / 9000		35	50	105
9500 / 12700			50	140

NARROW WRAPPED V-BELTS RMA

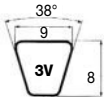

Oleostatic 3V SECTION

Code	External length LE (mm)	Code	External length LE (mm)	Code	External length LE (mm)	Code	External length LE (mm)	Code	External length LE (mm)	Code	External length LE (mm)	Code	External length LE (mm)
3V250	635	3V335	850	3V450	1145	3V600	1525	3V800	2030	3V1060	2690	3V1400	3555
3V265	675	3V355	900	3V475	1205	3V630	1600	3V850	2160	3V1120	2845	3V1500	3810
3V280	710	3V375	955	3V500	1270	3V670	1700	3V900	2285	3V1180	2995		
3V300	760	3V400	1015	3V530	1345	3V710	1805	3V950	2415	3V1250	3175		
3V315	800	3V425	1080	3V560	1420	3V750	1905	3V1000	2540	3V1320	3355		

TABLE 4 - P_b (kW) referred to \emptyset (mm)

RPM / \emptyset	63	71	80	90	100	112	125	140	150	160	170	180
100	0,10	0,13	0,16	0,20	0,24	0,28	0,33	0,38	0,41	0,45	0,48	0,52
200	0,18	0,24	0,30	0,37	0,44	0,52	0,61	0,71	0,78	0,85	0,91	0,98
500	0,39	0,52	0,67	0,83	0,99	1,19	1,39	1,63	1,79	1,94	2,10	2,25
700	0,51	0,69	0,89	1,11	1,34	1,60	1,88	2,20	2,42	2,63	2,84	3,05
900	0,62	0,85	1,10	1,38	1,66	1,99	2,35	2,75	3,02	3,28	3,55	3,81
1.000	0,67	0,92	1,20	1,51	1,82	2,18	2,57	3,02	3,31	3,60	3,89	4,17
1.400	0,87	1,21	1,59	2,01	2,42	2,92	3,44	4,03	4,43	4,81	5,19	5,57
1.500	0,91	1,28	1,68	2,13	2,57	3,09	3,65	4,28	4,69	5,10	5,50	5,90
1.700	1,00	1,41	1,86	2,36	2,85	3,43	4,05	4,75	5,21	5,66	6,10	6,54
1.800	1,04	1,47	1,95	2,47	2,99	3,60	4,25	4,98	5,46	5,93	6,39	6,84
2.500	1,31	1,88	2,52	3,21	3,89	4,68	5,52	6,45	7,05	7,63	8,19	8,74
2.900	1,44	2,09	2,81	3,59	4,35	5,23	6,16	7,17	7,82	8,44	9,04	9,60
3.000	1,47	2,14	2,88	3,68	4,46	5,36	6,31	7,34	8,00	8,63	9,22	9,79
3.400	1,58	2,32	3,14	4,02	4,87	5,85	6,86	7,95	8,63	9,27	9,87	10,43*
3.600	1,63	2,41	3,26	4,18	5,06	6,07	7,11	8,22	8,90	9,54	10,13*	10,68*
4.000	1,72	2,57	3,49	4,47	5,41	6,47	7,55	8,67	9,35*	9,97*		
5.000	1,88	2,87	3,93	5,04	6,07	7,19	8,26*					
6.000	1,94	3,03	4,18	5,35	6,39*							

P_d (kW) referred to i

RPM / i	1,00/1,01	1,02/1,05	1,06/1,11	1,12/1,18	1,19/1,26	1,27/1,38	1,39/1,57	1,58/1,94	1,95/3,38	over 3,39
100	0,00	0,00	0,00	0,01	0,01	0,01	0,01	0,01	0,02	0,02
200	0,00	0,00	0,01	0,01	0,02	0,02	0,03	0,03	0,03	0,03
500	0,00	0,01	0,02	0,03	0,05	0,06	0,06	0,07	0,08	0,08
700	0,00	0,01	0,03	0,05	0,06	0,08	0,09	0,10	0,11	0,12
900	0,00	0,01	0,03	0,06	0,08	0,10	0,12	0,13	0,14	0,15
1.000	0,00	0,01	0,04	0,07	0,09	0,11	0,13	0,15	0,16	0,17
1.400	0,00	0,02	0,05	0,09	0,13	0,15	0,18	0,20	0,22	0,23
1.500	0,00	0,02	0,06	0,10	0,14	0,17	0,19	0,22	0,24	0,25
1.700	0,00	0,02	0,07	0,11	0,15	0,19	0,22	0,25	0,27	0,29
1.800	0,00	0,03	0,07	0,12	0,16	0,20	0,23	0,26	0,29	0,30
2.500	0,00	0,04	0,10	0,17	0,23	0,28	0,32	0,36	0,40	0,42
2.900	0,00	0,04	0,11	0,19	0,26	0,32	0,37	0,42	0,46	0,49
3.000	0,00	0,04	0,12	0,20	0,27	0,33	0,39	0,44	0,48	0,50
3.400	0,00	0,05	0,13	0,23	0,31	0,38	0,44	0,49	0,54	0,57
3.600	0,00	0,05	0,14	0,24	0,33	0,40	0,47	0,52	0,57	0,60
4.000	0,00	0,06	0,15	0,27	0,36	0,44	0,52	0,58	0,63	0,67
5.000	0,00	0,07	0,19	0,33	0,46	0,55	0,65	0,73	0,79	0,84
6.000	0,00	0,08	0,23	0,40	0,55	0,66	0,78	0,87	0,95	1,01



* Belt speed is greater than 30 m/s then is necessary to use dynamically balanced pulleys. A reduction in belt life can be expected. Suggested a smaller section.

NARROW WRAPPED V-BELTS RMA

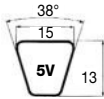

Oleostatic 5V SECTION

Code	External length LE (mm)	Code	External length LE (mm)	Code	External length LE (mm)	Code	External length LE (mm)	Code	External length LE (mm)	Code	External length LE (mm)	Code	External length LE (mm)
5V500	1270	5V670	1700	5V900	2290	5V1180	3000	5V1600	4060	5V2120	5380	5V2800	7100
5V530	1345	5V710	1800	5V950	2410	5V1250	3180	5V1700	4320	5V2240	5690	5V3000	7620
5V560	1420	5V750	1900	5V1000	2540	5V1320	3350	5V1800	4570	5V2360	6000	5V3150	8000
5V600	1525	5V800	2030	5V1060	2690	5V1400	3550	5V1900	4830	5V2500	6350	5V3350	8500
5V630	1600	5V850	2160	5V1120	2840	5V1500	3810	5V2000	5080	5V2650	6730	5V3550	9000

TABLE 4 - P_b (kW) referred to Ø (mm)

RPM / Ø	140	150	160	170	180	200	225	250	280	315	355	400
100	0,66	0,75	0,85	0,94	1,04	1,22	1,45	1,69	1,96	2,28	2,64	3,04
200	1,20	1,38	1,56	1,74	1,92	2,28	2,70	3,16	3,68	4,29	4,97	5,74
500	2,60	3,02	3,45	3,87	4,29	5,12	6,11	7,16	8,37	9,76	11,33	13,06
700	3,43	4,00	4,58	5,15	5,72	6,85	8,18	9,61	11,23	13,08	15,16	17,43
900	4,19	4,92	5,64	6,35	7,06	8,47	10,13	11,89	13,88	16,15	18,66	21,38
1.000	4,56	5,35	6,14	6,93	7,71	9,24	11,05	12,98	15,14	17,59	20,29	23,18
1.400	5,88	6,95	8,00	9,04	10,07	12,09	14,44	16,90	19,62	22,62	25,81	29,05
1.500	6,19	7,31	8,43	9,53	10,61	12,73	15,20	17,77	20,60	23,68	26,92	30,14*
1.700	6,75	8,00	9,23	10,44	11,63	13,95	16,62	19,38	22,36	25,54	28,77*	
1.800	7,02	8,32	9,60	10,86	12,10	14,51	17,27	20,10	23,13	26,33	29,49*	
2.000	7,51	8,92	10,30	11,66	12,98	15,55	18,46	21,39	24,47	27,60*		
2.500	8,51	10,14	11,73	13,27	14,76	17,58	20,65	23,58*				
2.900	9,05	10,82	12,52	14,14	15,69	18,55*	21,52*					
3.000	9,15	10,94	12,66	14,30	15,85	18,69*						
3.500	9,40	11,27	13,02	14,65*	16,16*							
3.600	9,40	11,27	13,02	14,64*	16,12*							
4.000	9,21	11,06*	12,75*									
4.600	8,33*											

P_d (kW) referred to i

RPM / i	1,00/1,01	1,02/1,05	1,06/1,11	1,12/1,18	1,19/1,26	1,27/1,38	1,39/1,57	1,58/1,94	1,95/3,38	over 3,39
100	0,00	0,01	0,02	0,03	0,05	0,06	0,07	0,07	0,08	0,09
200	0,00	0,01	0,04	0,07	0,09	0,11	0,13	0,15	0,16	0,17
500	0,00	0,04	0,10	0,17	0,23	0,28	0,33	0,37	0,41	0,43
700	0,00	0,05	0,14	0,24	0,33	0,40	0,47	0,52	0,57	0,61
900	0,00	0,07	0,18	0,31	0,42	0,51	0,60	0,67	0,73	0,78
1000	0,00	0,07	0,20	0,34	0,47	0,57	0,67	0,75	0,82	0,86
1400	0,00	0,10	0,28	0,48	0,66	0,80	0,93	1,05	1,14	1,21
1500	0,00	0,11	0,30	0,52	0,70	0,85	1,00	1,12	1,22	1,30
1700	0,00	0,12	0,34	0,59	0,80	0,97	1,13	1,27	1,39	1,47
1800	0,00	0,13	0,36	0,62	0,84	1,02	1,20	1,35	1,47	1,56
2000	0,00	0,15	0,40	0,69	0,94	1,14	1,33	1,50	1,63	1,73
2500	0,00	0,18	0,49	0,86	1,17	1,42	1,66	1,87	2,04	2,16
2900	0,00	0,21	0,57	1,00	1,36	1,65	1,93	2,17	2,37	2,51
3000	0,00	0,22	0,59	1,03	1,41	1,71	2,00	2,25	2,45	2,59
3500	0,00	0,25	0,69	1,21	1,64	1,99	2,33	2,62	2,86	3,03
3600	0,00	0,26	0,71	1,24	1,69	2,05	2,40	2,70	2,94	3,11
4000	0,00	0,29	0,79	1,38	1,88	2,27	2,66	3,00	3,27	3,46
4600	0,00	0,33	0,91	1,59	2,16	2,62	3,06	3,45	3,76	3,98

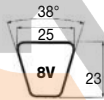

Oleostatic 8V SECTION

Code	External length LE (mm)	Code	External length LE (mm)	Code	External length LE (mm)	Code	External length LE (mm)	Code	External length LE (mm)	Code	External length LE (mm)	Code	External length LE (mm)
8V1000	2540	8V1250	3180	8V1600	4060	8V2000	5080	8V2500	6350	8V3150	8000	8V4000	10160
8V1060	2690	8V1320	3350	8V1700	4320	8V2120	5380	8V2650	6730	8V3350	8500	8V4250	10800
8V1120	2840	8V1400	3550	8V1800	4570	8V2240	5690	8V2800	7100	8V3550	9000	8V4500	11430
8V1180	3000	8V1500	3810	8V1900	4830	8V2360	6000	8V3000	7620	8V3750	9500	8V4750	12060
												8V5000	12700

TABLE 4 - P_b (kW) referred to d (mm)

RPM / Ø	315	335	355	375	400	425	475	530	600	670	750	800
50	2,36	2,62	2,89	3,15	3,48	3,80	4,45	5,16	6,06	6,95	7,96	8,58
100	4,35	4,86	5,36	5,87	6,49	7,12	8,36	9,71	11,42	13,11	15,03	16,22
150	6,21	6,95	7,68	8,42	9,33	10,24	12,04	14,01	16,49	18,95	21,73	23,45
200	7,97	8,93	9,89	10,85	12,04	13,22	15,58	18,14	21,36	24,55	28,15	30,37
300	11,28	12,68	14,07	15,46	17,18	18,89	22,29	25,97	30,59	35,13	40,23	43,36
400	14,37	16,19	17,99	19,79	22,01	24,22	28,58	33,30	39,18	44,93	51,32	55,21
500	17,28	19,49	21,68	23,86	26,56	29,23	34,48	40,14	47,14	53,90	61,33	65,79
600	20,01	22,59	25,15	27,69	30,82	33,92	39,99	46,47	54,40	61,97	70,13	74,95
750	23,77	26,88	29,94	32,97	36,69	40,34	47,44	54,90	63,86	72,15	80,74	85,59*
900	27,15	30,71	34,21	37,65	41,86	45,96	53,83	61,94	71,36	79,69*		
1000	29,17	33,00	36,75	40,43	44,89	49,22	57,44	65,76	75,14*			
1200	32,61	36,89	41,03	45,05	49,87	54,47	62,93	71,05*				
1400	35,20	39,77	44,14	48,31	53,23	57,80*	65,83*					
1500	36,15	40,80	45,22	49,39	54,24*	58,68*						
1700	37,29	41,97	46,32*	50,32*								
1800	37,45	42,07*	46,31*									
1900	37,34*	41,84*										
2000	36,93*											

P_d (kW) referred to i

RPM / i	1,00/1,01	1,02/1,05	1,06/1,11	1,12/1,18	1,19/1,26	1,27/1,38	1,39/1,57	1,58/1,94	1,95/3,38	over 3,39
50	0,00	0,02	0,05	0,09	0,13	0,16	0,18	0,21	0,22	0,24
100	0,00	0,04	0,11	0,19	0,26	0,31	0,37	0,41	0,45	0,47
150	0,00	0,06	0,16	0,28	0,39	0,47	0,55	0,62	0,67	0,71
200	0,00	0,08	0,22	0,38	0,52	0,62	0,73	0,82	0,90	0,95
300	0,00	0,12	0,32	0,57	0,77	0,94	1,10	1,24	1,35	1,42
400	0,00	0,16	0,43	0,76	1,03	1,25	1,46	1,65	1,79	1,90
500	0,00	0,20	0,54	0,94	1,29	1,56	1,83	2,06	2,24	2,37
600	0,00	0,24	0,65	1,13	1,55	1,87	2,19	2,47	2,69	2,85
750	0,00	0,30	0,81	1,42	1,93	2,34	2,74	3,09	3,36	3,56
900	0,00	0,36	0,97	1,70	2,32	2,81	3,29	3,71	4,04	4,27
1000	0,00	0,40	1,08	1,89	2,58	3,12	3,66	4,12	4,49	4,75
1200	0,00	0,48	1,30	2,27	3,09	3,75	4,39	4,94	5,38	5,70
1400	0,00	0,56	1,52	2,64	3,61	4,37	5,12	5,77	6,28	6,65
1500	0,00	0,60	1,62	2,83	3,87	4,68	5,49	6,18	6,73	7,12
1700	0,00	0,68	1,84	3,21	4,38	5,31	6,22	7,00	7,62	8,07
1800	0,00	0,72	1,95	3,40	4,64	5,62	6,58	7,41	8,07	8,55
1900	0,00	0,76	2,06	3,59	4,90	5,93	6,95	7,83	8,52	9,02
2000	0,00	0,79	2,17	3,78	5,15	6,24	7,32	8,24	8,97	9,50

* Belt speed is greater than 30 m/s then is necessary to use dynamically balanced pulleys. A reduction in belt life can be expected. Suggested a smaller section.

DATA SHEET FOR CALCULATION

CUSTOMER DATA

Date ____/____/____

Company Name _____
 Address _____ Zip Code _____
 City _____ State _____ Country _____
 Customer Name/Surname _____
 Office _____ Tel. _____ Fax _____
 e-mail _____

Application field _____

Volume: _____

 New

 Existing*

*Please enclose to this request all the details of the existing application (competitor's belt, current data, etc..)

POWER TRANSMISSION TRANSMISSION LAYOUT

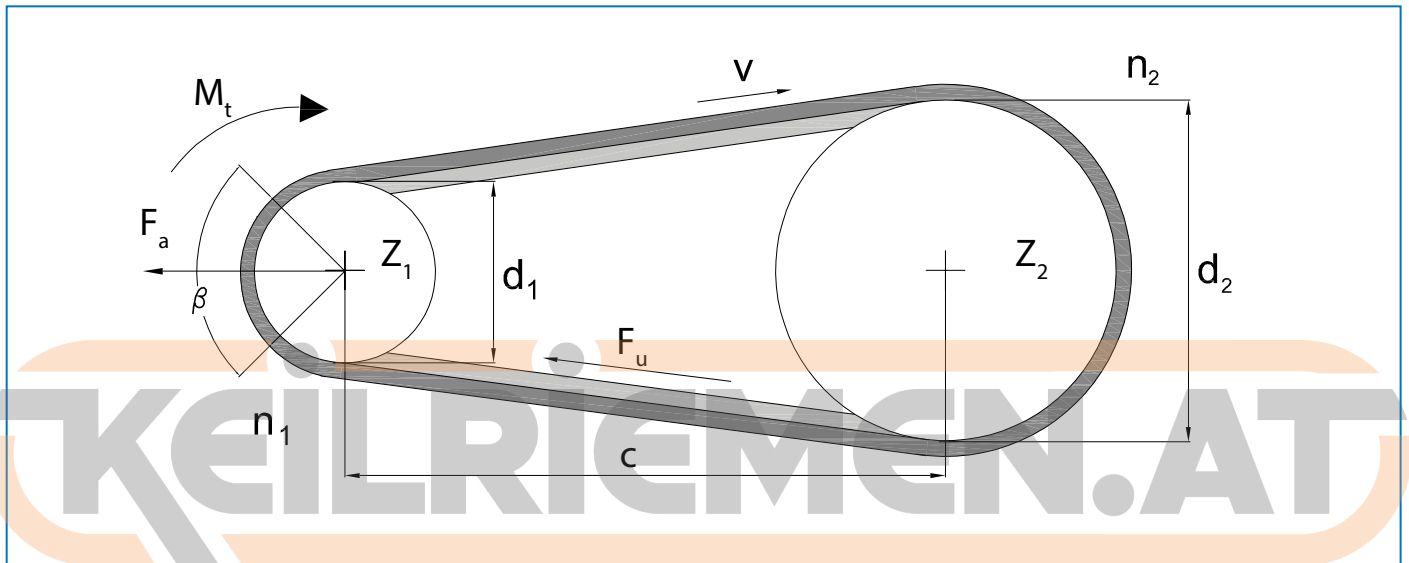

If layout is different please sketch it below

DRIVE INFORMATION

MOTOR:

AC DC Soft Start Inverter
 Power: _____
 Speed: _____
 Torque: _____
 Acceleration: _____
 Working time: < 8h From 8h up to 16h >16h

APPLICATION:

Driver pulley diameter: _____
 Driven pulley diameter: _____
 Center distance: _____
 Minimum safety factor required: _____
 Are there any size limitation? Yes No
 (if yes please indicate):
 diameter (min. and/or max.): _____
 width (min. and/or max.): _____
 center distance: (min. and/or max.) _____